



**UNIVERSITY
OF OULU**

**KERTTU SAALASTI
INSTITUTE**

***Science
With
Arctic
Attitude!***

FMT
FUTURE MANUFACTURING
TECHNOLOGIES



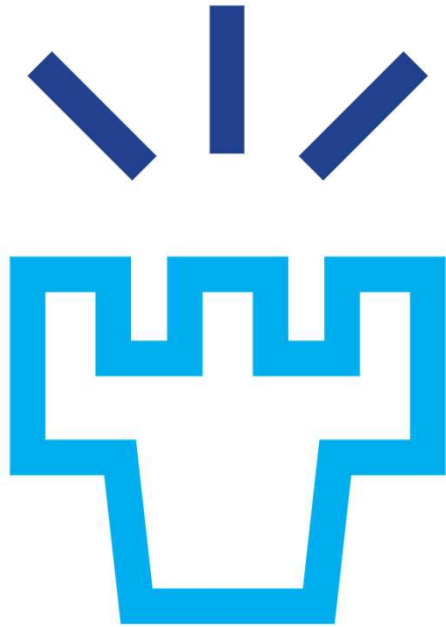

**UNIVERSITY
OF OULU**

KERTTU SAALASTI INSTITUTE

Metal 3D Printing

FMT
FUTURE MANUFACTURING
TECHNOLOGIES

UNIVERSITY OF OULU
KERTTU SAALASTI INSTITUTE

FMT

FUTURE MANUFACTURING
TECHNOLOGIES

C3TS

Arctic platform to Create, 3D-print, Test and Sell



In cooperation with



TROMS County Council
TROMS fylkeskommune

**Interreg
Pohjoinen**

Euroopan aluekehitysrahasto



EUROOPAN UNIONI



LAPIN LIITTO



Science
with
Arctic
Attitude



UNIVERSITY OF OULU
KERTTU SAALASTI INSTITUTE

FMT

FUTURE MANUFACTURING
TECHNOLOGIES





Sisältö



- Opening words
- Additive manufacturing and AM methods
- **Designing with AM in mind**
 - Design process in general
 - Designing with the SLM method
- **Utilizing AM in industry**
 - Prospects
 - Commercial service providers
- **Conclusion**



FMT

FUTURE MANUFACTURING
TECHNOLOGIES



Kari Mäntyjärvi
Research Director

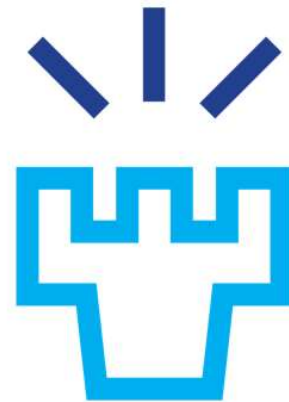

UNIVERSITY
OF OULU
KERTTU SAALASTI INSTITUTE



Tero Jokelainen
Project Researcher
AM Expert





Future Manufacturing Technologies (FMT) group

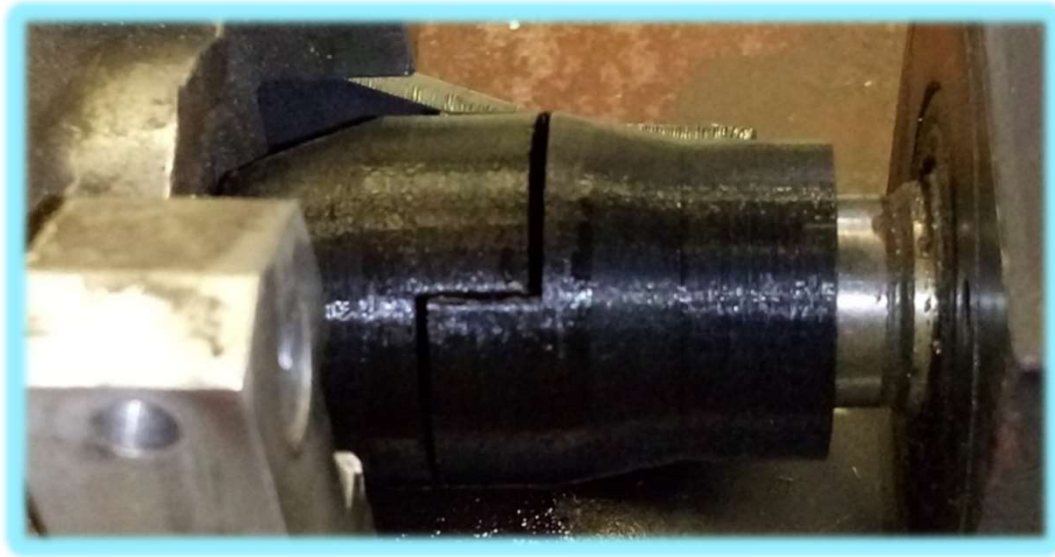

Resources

- 18 people, operations in Nivala (ELME Studio), Oulu (Linnanmaa campus) and Raahel (Aiku)
- diverse equipment access – from laser machining to material machining and research
- University of Oulu's Mechanical Engineering department ja Jedu's metal expertise as support

Research

- Over 60 international academic publications between 2007-2017
- Publically funded international and national projects and research commissions
- Fueled by the need of the local companies, usability of the results over a period of 0-5 years.

Business services

- Yearly around 50 company commissioned research cases
- Research cases, prototypes and consulting

Theses

- 19 MSE and 35 engineers

International cooperation

- Sweden, Egypt, Norway, Iceland, Ireland, Scotland, Germany, France, Poland, Iran ja India
- Collaboration with international equipment and technology developers





FMT research – Focus areas



Light and rigid structures + Laser technology application

- Materials, design and manufacturing
- Honeycomb technique, molding, welding research
- Utilization of ultra strong materials
- Utilization of simulation

Special steels – from steel to products

- Small series steel
- Molding and special processes
- Effects of fatigue loading
- Metallography

Additive manufacturing and applying it to other manufacturing techniques

- Materials, design and manufacturing

Cost-effective production automation

- Tailored automation
- Production monitoring
- Digitalization and industrial internet



C3TS

Arctic platform to Create, 3D-print, Test and Sell





C3TS

Arctic platform to Create, 3D-print, Test and Sell

C3TS is funded by the Interreg Nord program and lead by Luleå University of Technology, where FMT operates as an associate partner.

The overall goal of the project is to improve international competitiveness of SMEs by making metal 3D-printing known as a viable manufacturing method.

Metal 3D printing technology makes it possible to have more innovative designs, cut down manufacturing costs and make a smaller impact on the environment with less used material and manufacturing steps than are in traditional manufacturing techniques.



Interreg
Pohjoinen
Euroopan aluekehitysrahasto



EUROOPAN UNIONI



LAPIN LIITTO



TROMS County Council
TROMS fylkeskommune



Science
with
Arctic
Attitude



UNIVERSITY OF OULU
KERTTU SAALASTI INSTITUTE

FMT

FUTURE MANUFACTURING
TECHNOLOGIES



UNIVERSITY OF OULU
KERTTU SAALASTI INSTITUTE

FMT

FUTURE MANUFACTURING
TECHNOLOGIES

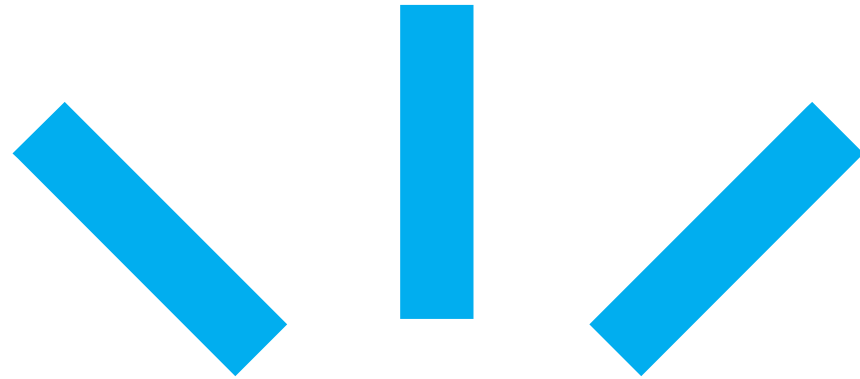

Additive Manufacturing and its methods



Additive Manufacturing

3D Printing



- **Additive Manufacturing**
- Material adding manufacturing method
- 3D printing
- A group of manufacturing techniques based in adding material (as oppsed to removal or attaching processes)
 - Broadly every technique where a part is produced by adding material
- Methods:
 - Powder Bed Fusion
 - Material Extrusion
 - Vat Photopolymerization
 - Material Jetting
 - Binder Jetting
 - Directed Energy Deposition
 - Sheet Lamination



From 3D model to printed product

- **Taking the method into account when designing the product**
 - Need of support structures, effect of printing orientation, minimizing post-processing, anisotropic effect of the material
- **Preparing the designed product for printing with pre-treatment software**
 - Placing the part on the printing platform
 - Determining the support structures
 - Choosing and placing the printing parameters
- **Defining the program (automatic)**
 - Dividing the structure to layers
 - Forming layer trajectories
- **Transferring to the printer**
- **Printing**

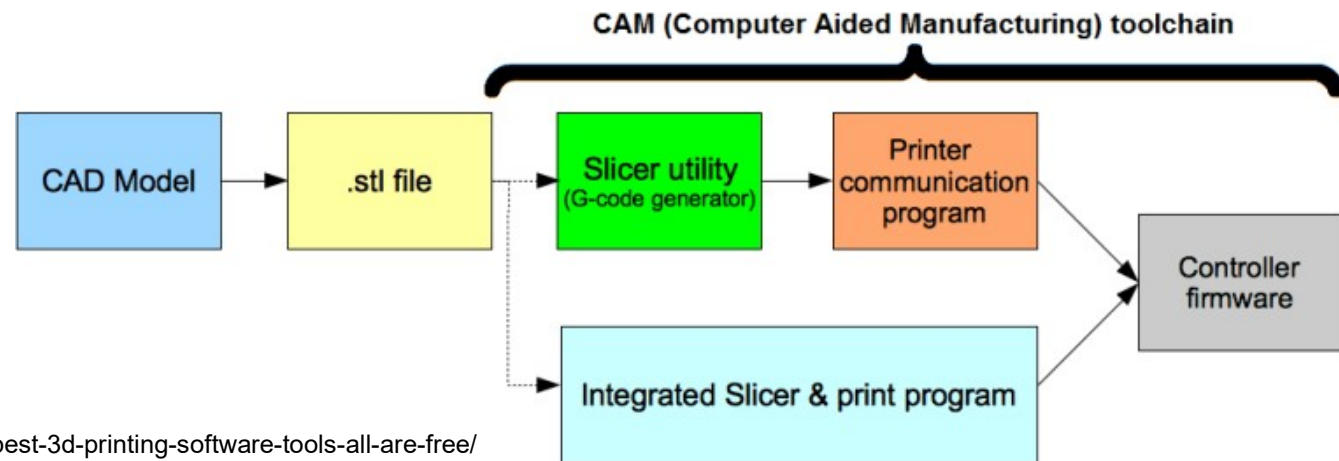



Programming the 3D printer Free softwares for printing

KISSlicer	Slicer	Intermediate	Windows, Mac, Linux	KISSlicer
Slic3r	Slicer	Intermediate	Windows, Mac, Linux	Slic3r
SliceCrafter	Slicer	Intermediate	Browser	SliceCrafter
Cura	Slicer, 3D Printer Host	Beginner	Windows, Mac, Linux	Cura
OctoPrint	Slicer, 3D Printer Host	Intermediate	Windows, Mac, Linux, Raspbian (as OctoPi image)	OctoPrint
Repetier-Host	Slicer, 3D Printer Host	Intermediate	Windows, Mac, Linux	Repetier
AstroPrint	Slicer, 3D Printer Host	Beginner	Browser	AstroPrint
MatterControl 2.0	Slicer, 3D Printer Host, Design	Beginner	Windows, Mac, Linux	MatterControl
IceSL	Slicer, Design	Intermediate	Windows, Linux	IceSL
3D-Tool Free Viewer	STL Analysis	Intermediate	Windows	3d-Tool Viewer
MakePrintable	STL Editor, STL Repair	Intermediate	Browser	MakePrintable
Meshmixer	STL Editor, STL Repair	Intermediate	Windows, Mac	Meshmixer
MeshLab	STL Editor, STL Repair	Professional	Windows, Mac, Linux	MeshLab
3DPrinterOS	STL Editor, STL Repair, Slicer, 3D Printer Host	Beginner	Windows, Mac, Ubuntu, Raspberry Pi	3DPrinterOS
Netfabb	STL Repair, Slicer	Professional	Windows	Netfabb

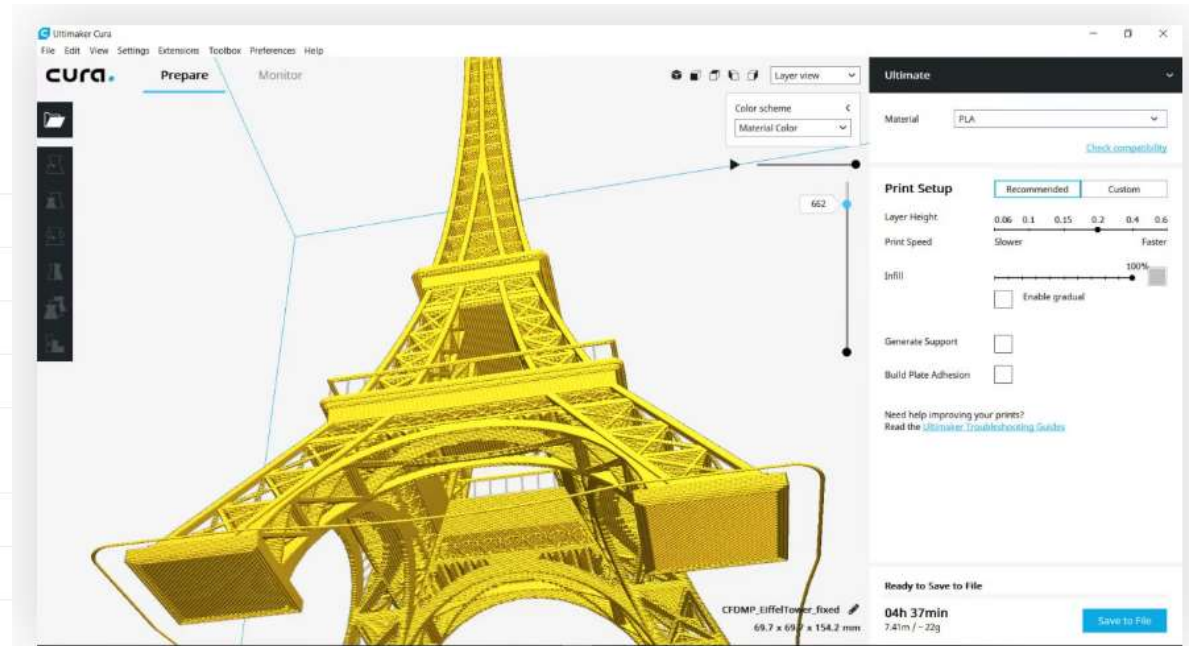

Cura settings can be quite extensive. (Source: All3DP)

FEATURES

Software	Cura	Price	Free
Function	Slicer, 3D Printer Host	System	Windows, Mac, Linux
Level	Beginner	Download/Visit:	Cura

<https://all3dp.com/1/best-free-3d-printing-software-3d-printer-program/>



Identifying AM method's potential, selection and design process according to Standard ISO/ASTM 52910:20

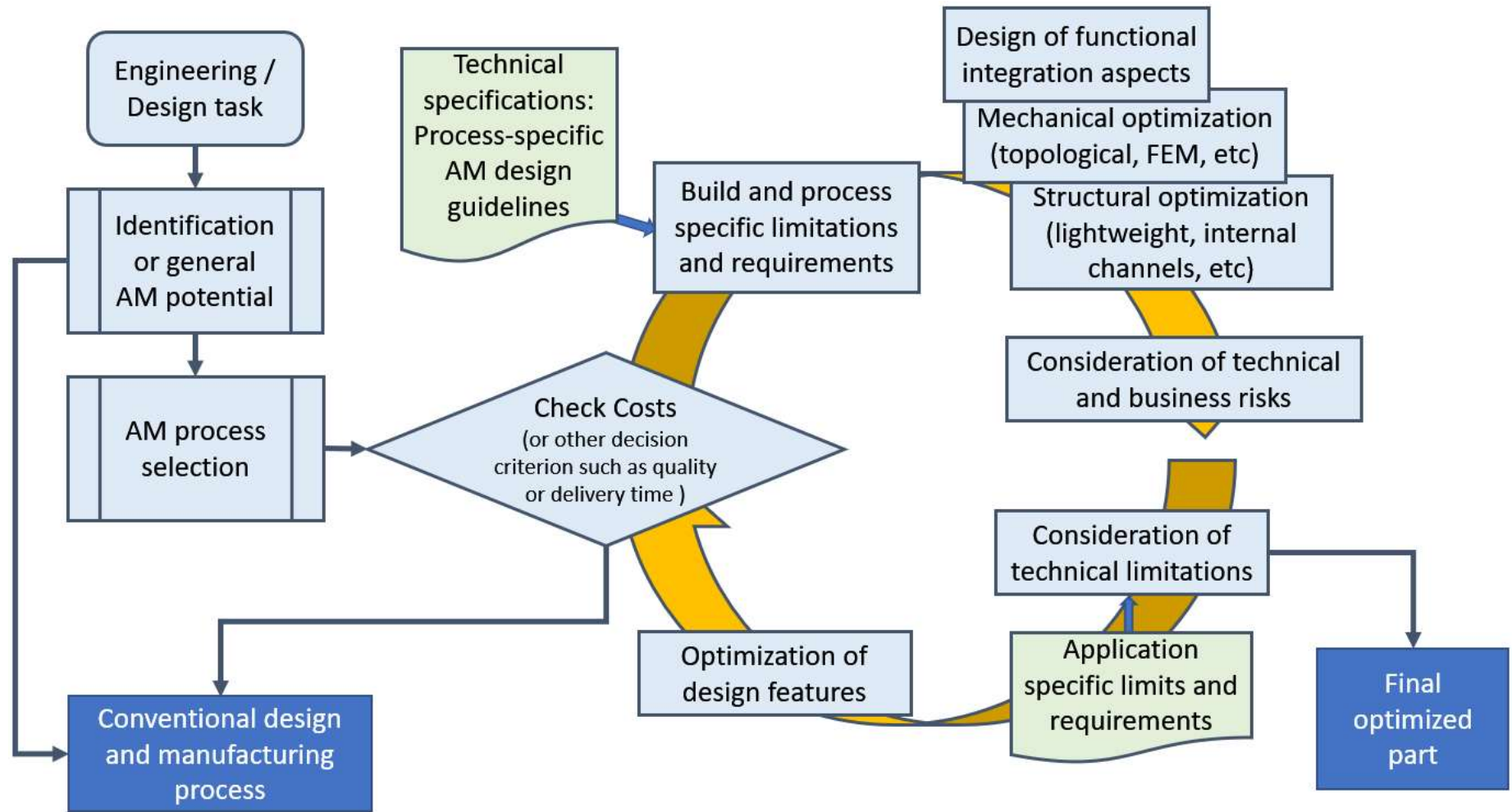



Different AM processes

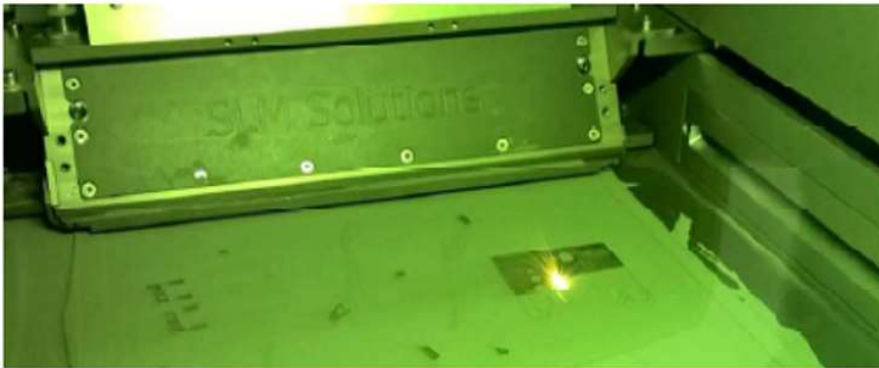

Picture: FMT



- Single phase \leftrightarrow Multiphase
- Material (metal, polymer, ceramic)
- Joining process for the material (fusing vs attaching)
- Initial stage of the substance

- More information:
<https://www.3dhubs.com/knowledge-base>

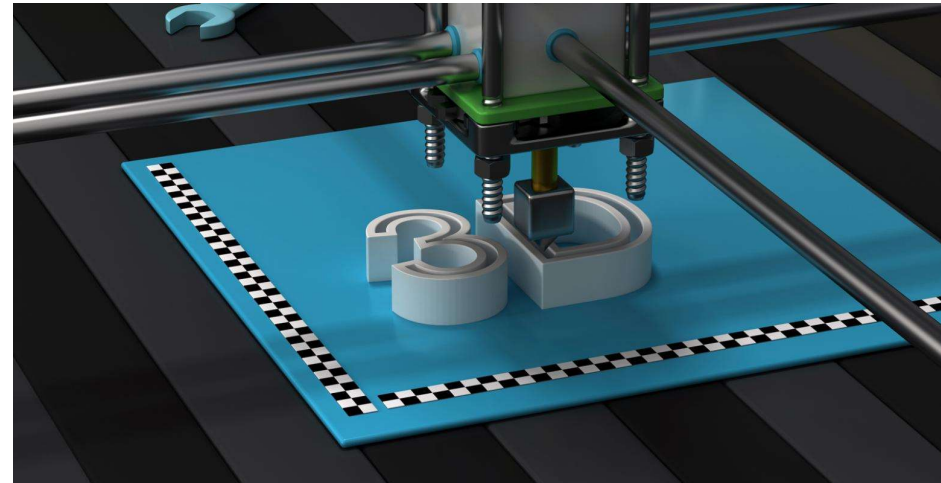

Picture: <https://www.machinedesign.com>



ISO/ASTM 52900:2015(E)

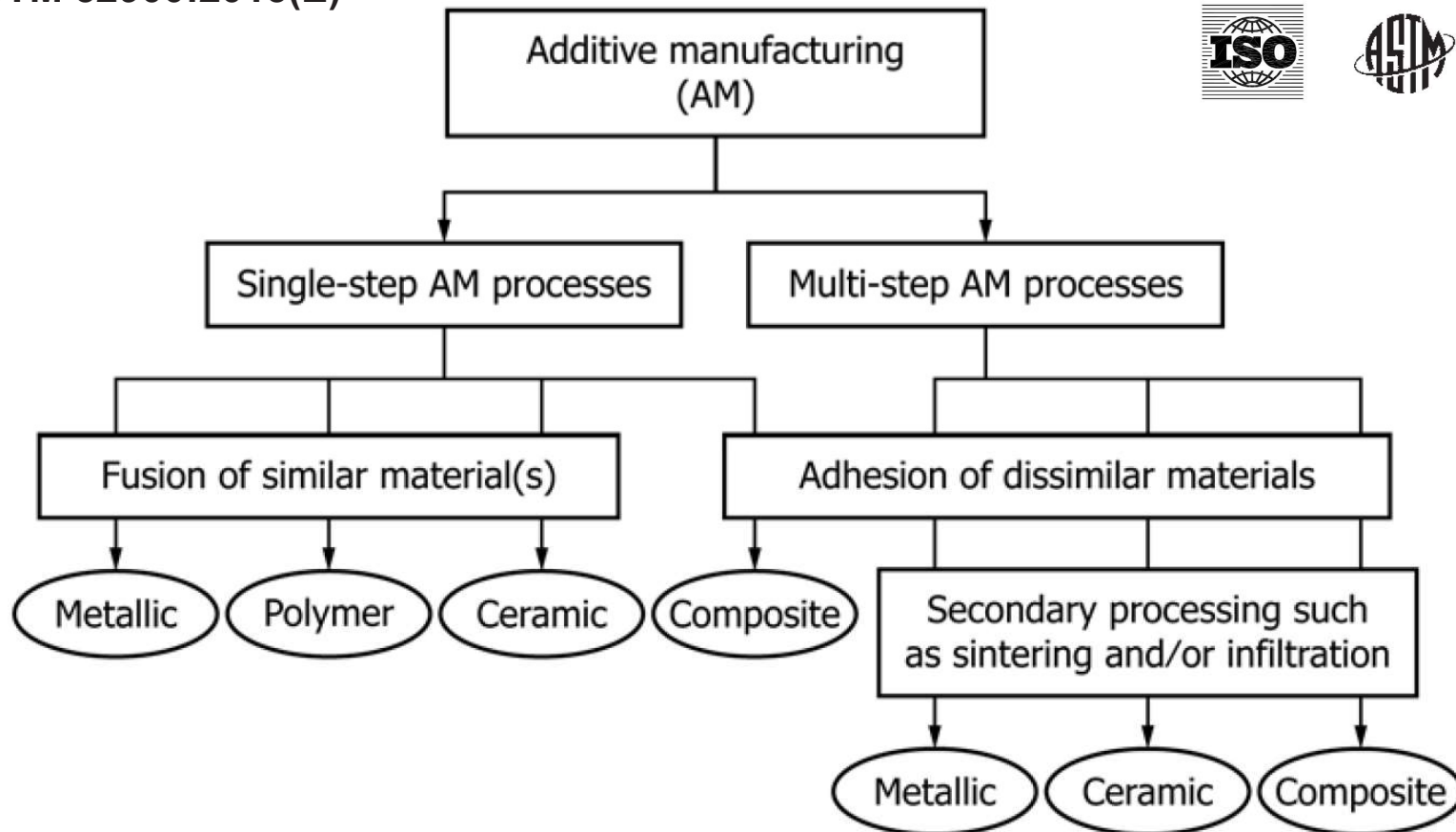

FIG. A1.1 Single-step and Multi-step AM process principles



- Powder Bed Fusion
 - Laser Powder Bed Fusion
 - Selective Laser Melting
 - Selective Laser Sintering
 - (Selective) Electron-Beam Melting
- Direct Energy Deposition
 - Direct Laser Deposition
 - Electron-Beam Deposition

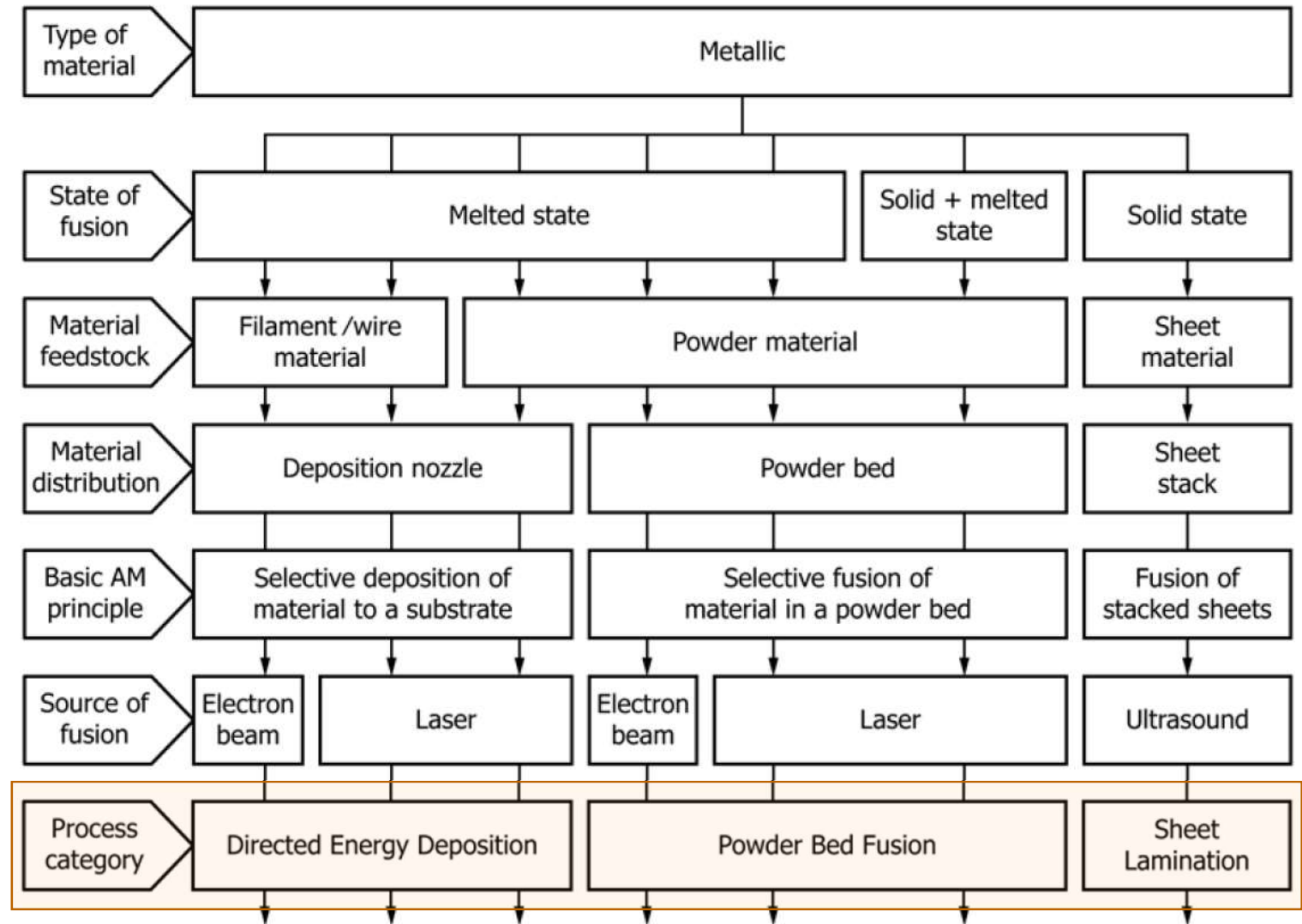
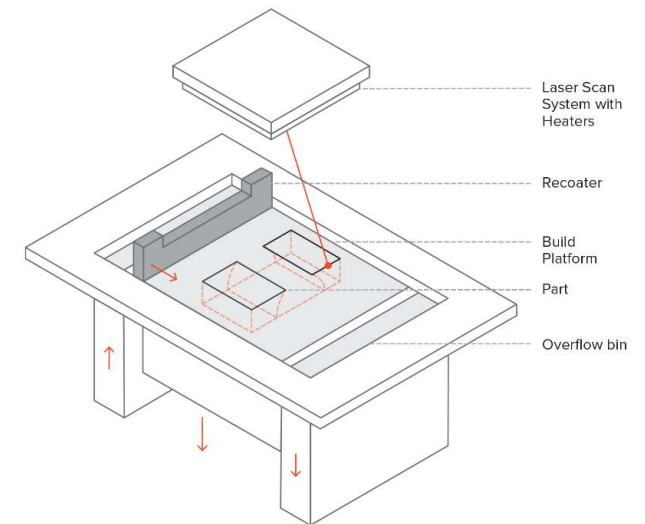
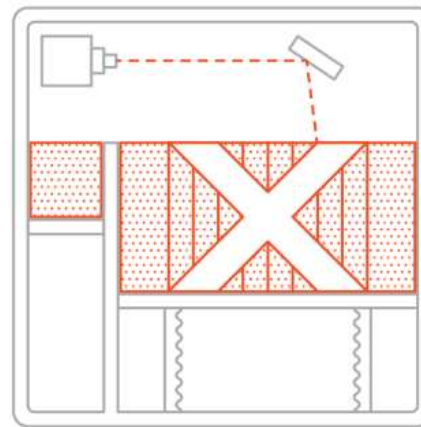
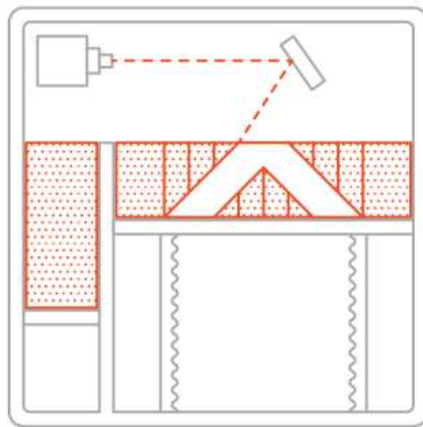
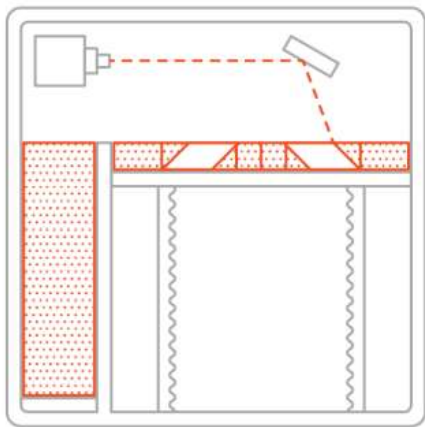

FIG. A1.2 Overview of single-step AM processing principles for metallic materials



Selective Laser Melting

- Most common metal 3D printing method
- Direct Metal Laser Sintering – Almost the same, except the metal is not melted but heated to sintering temperature – less laser power needed
- Metal powder is melted layer by layer with a laser
- The structure is deposited onto the platform
- Support structures necessary (same material as product)
- Most common materials AISI 316L (acid and rust resistant) and AISI10Mg (aluminum)
 - Titanium alloys, tool steels, super alloys etc.
 - Basic carbon steels won't work



Source: <https://www.3dhubs.com/knowledge-base/introduction-metal-3d-printing>

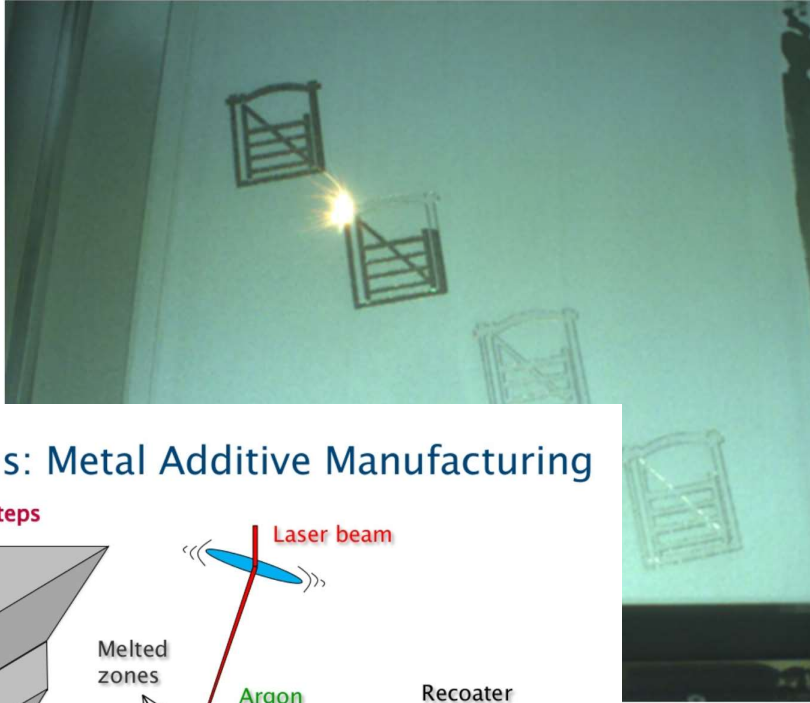

Generalities: Metal Additive Manufacturing

The building steps

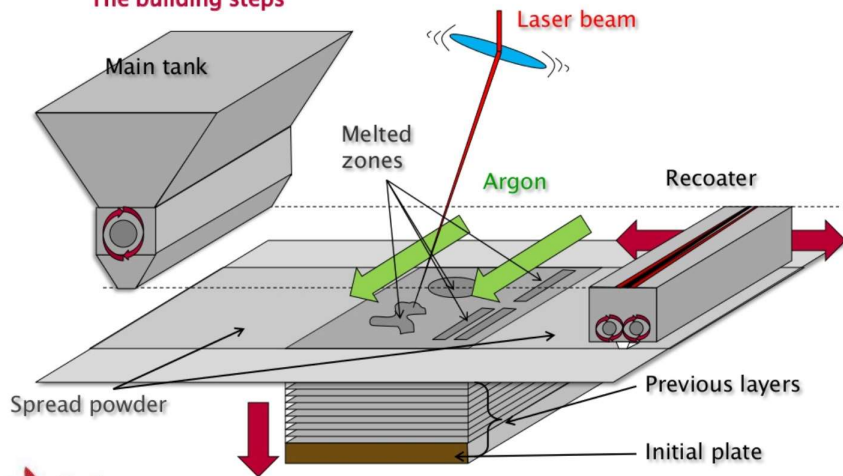

© Sirris | www.sirris.be | info@sirris.be | 25/11/2013 13



<https://www.3dprintingmedia.network/slm-solutions-presents-upgraded-slm-280-2-0-3d-printer-tire-technology-exhibition/>



AlSi10Mg

SLM Solutions' Al-Alloy AlSi10Mg is an aluminum-based alloy that is widely used in the additive manufacturing industry for production of functional parts as well as prototypes. AlSi10Mg is often used in applications requiring good mechanical properties and low weight.

Chemical Composition (nominal), %

Element / Material	Al	Si	Mg	Cu	Fe	Mn	Zn	Ti	Ni	Pb	Sn	Others	Total Others
AlSi10Mg 20-63 µm	Bal.	9.00-11.00	0.20 - 0.45	0.05	0.55	0.45	0.10	0.15	0.05	0.05	0.05	0.05	0.15

Mechanical Data⁵

Formula Symbol and Unit

AlSi10Mg^{2,3}

Tensile strength	R _m [MPa]	386 ± 42
Offset yield stress	R _{p0,2} [MPa]	268 ± 8
Break strain	A [%]	6 ± 1
Reduction of area	Z [%]	7 ± 1
E-Modul	E [GPa]	61 ± 9
Hardness by Vickers	[HV10]	122 ± 2
Surface roughness	R _a [µm]	8 ± 1
Surface roughness	R _z [µm]	63 ± 10

Material Characteristics

- Very good corrosion resistance
- Good electrical conductivity
- High dynamic toughness
- Excellent thermal conductivity

Typical Application Areas

- Aerospace
- Automotive
- Engineering
- Heat exchangers



316L

SLM Solutions' Stainless Steel 316L is an austenitic high chromium steel with excellent processability on SLM Solutions' additive manufacturing machines. 316L is often used in applications requiring good mechanical properties and excellent corrosion resistance, especially in chloride environments.

Chemical Composition (nominal), %

Element / Material	Fe	Cr	Ni	Mo	Si	Mn	C	N	P	S	O
316L (1.4404) 10-45 µm	Bal.	16.00 - 18.00	10.00 - 14.00	2.00 - 3.00	1.00	2.00	0.030	0.10	0.045	0.030	0.10

Mechanical Data ⁵	Formula Symbol and Unit	1.4404 / 316L ^{2,3}
Tensile strength	R_m [MPa]	633 ± 28
Offset yield stress	$R_{p0,2}$ [MPa]	519 ± 25
Break strain	A [%]	31 ± 6
Reduction of area	Z [%]	49 ± 11
E-Modul	E [GPa]	184 ± 20
Hardness by Vickers	[HV10]	209 ± 2
Surface roughness	R_a [µm]	10 ± 2
Surface roughness	R_z [µm]	50 ± 12

Material Characteristics

- Very good corrosion resistance
- High strength under elevated temperatures
- High ductility

Typical Application Areas

- Aerospace /Automotive
- Surgical Instruments
- Food Industry
- Maritime

Source: <https://slm-solutions.com/>



Direct Laser Deposition

- Powder or wire is fused directly onto the target
- Even though the machines operate by layering the material, they are often multi-axis
- Adding detail to pre-existing structures
- Not (yet) as precise as the SLM method, but it is faster
- Technique similar to laser injection blasting (laser coating)

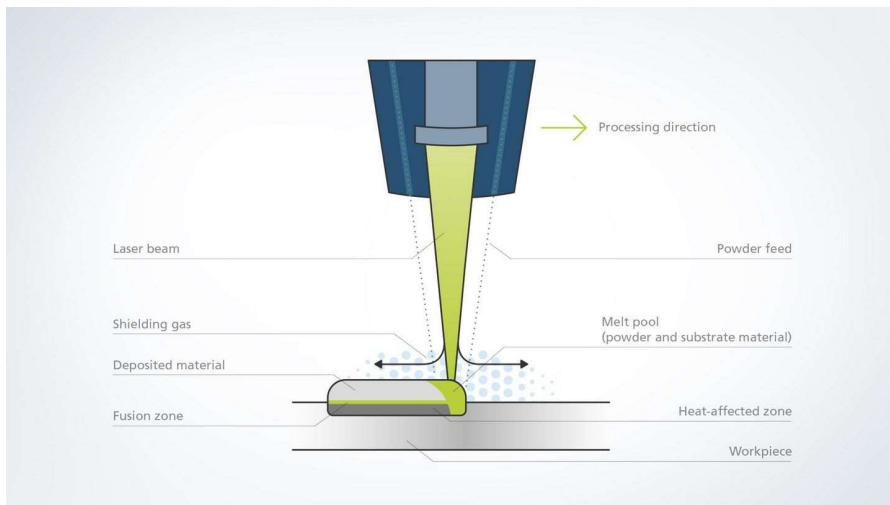

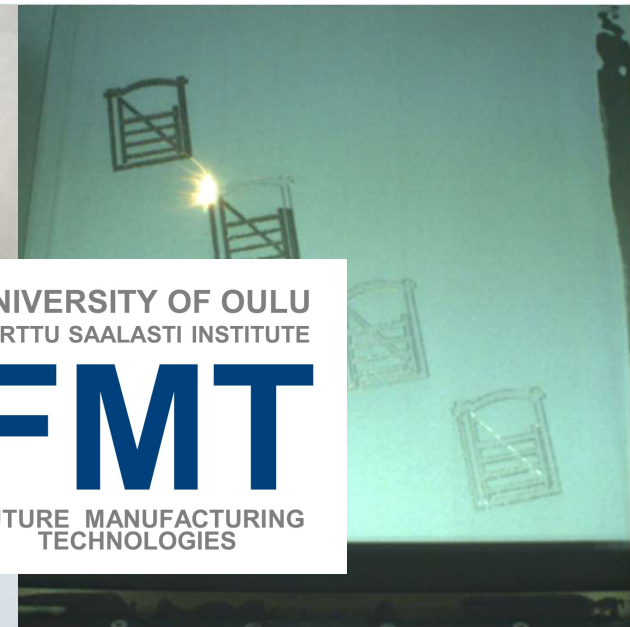
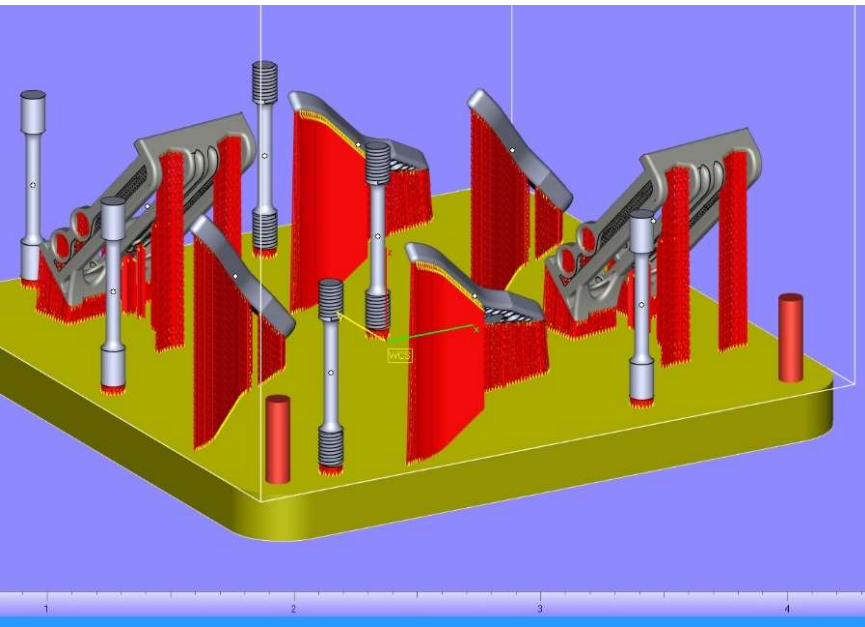

UNIVERSITY OF OULU
KERTTU SAALASTI INSTITUTE
FMT
FUTURE MANUFACTURING
TECHNOLOGIES





- Extrusion
 - Fused Filament Fabrication / Fused Deposition Modelling
- Powder Bed
 - Selective Laser Sintering
- Jetting
 - Binder jetting
 - Material jetting
- Photopolymerization

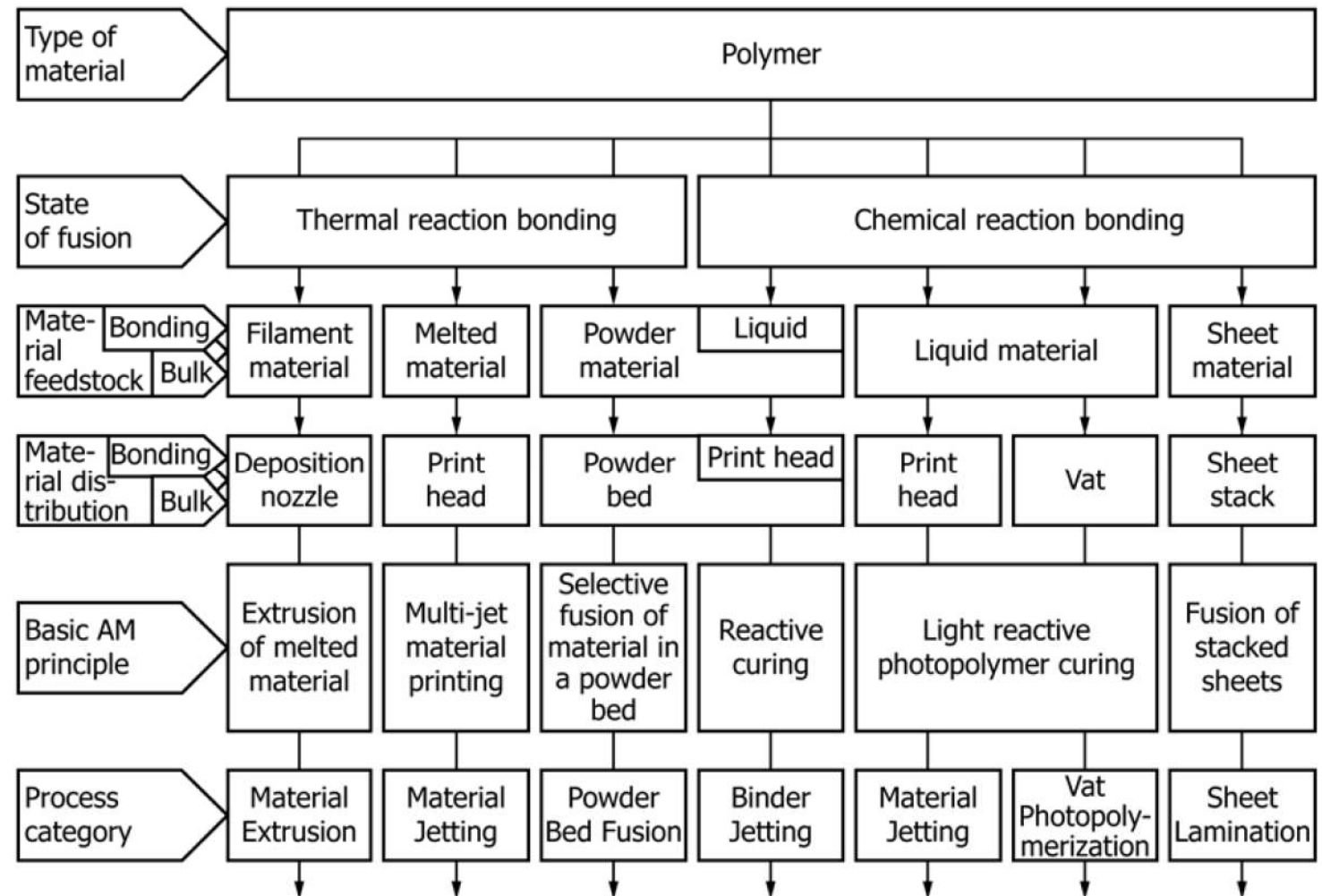

FIG. A1.3 Overview of single-step AM processing principles for polymer materials





Fused Deposition Modelling

- Another used term "Fused Filament Fabrication"
- Most common 3D printing method
- Based on the heating of polymer wire and extruding it layer by layer into the designed shape
- Multitude of machines from inexpensive home devices to industrial printers
- Multimaterial printing
- Support structures needed in some cases
- Diverse source of materials for different needs
"From chocolate to PEEK...."
- Layered structure, not very accurate

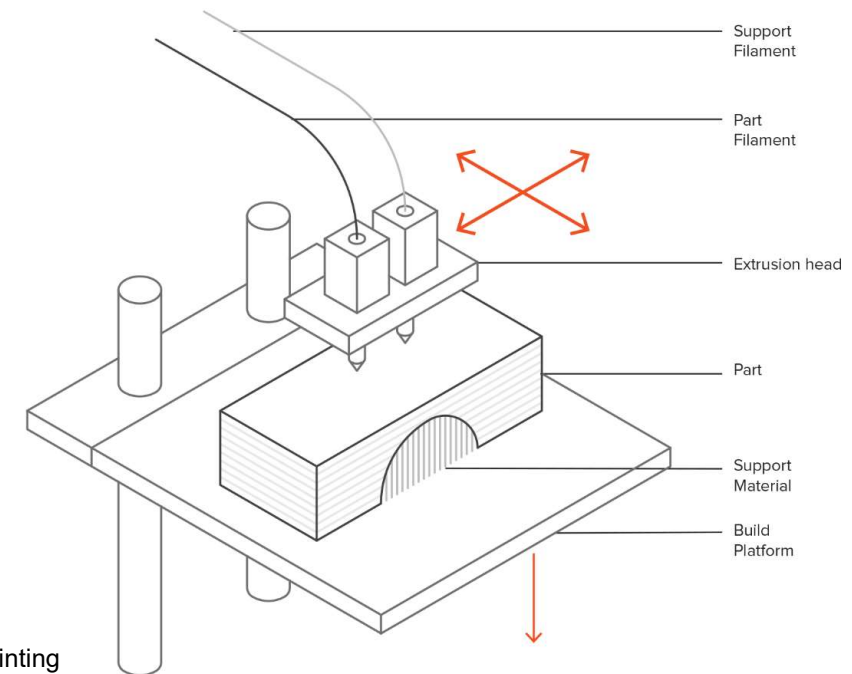
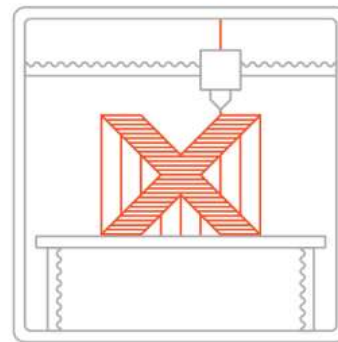
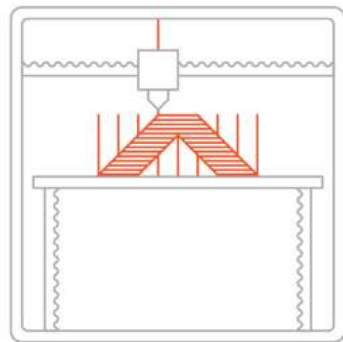
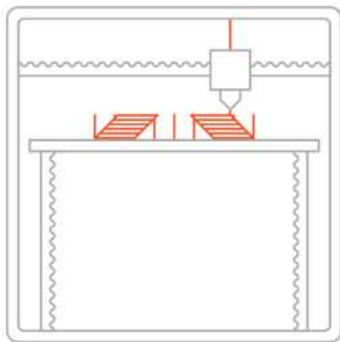

Source: <https://www.3dhubs.com/knowledge-base/introduction-fdm-3d-printing>

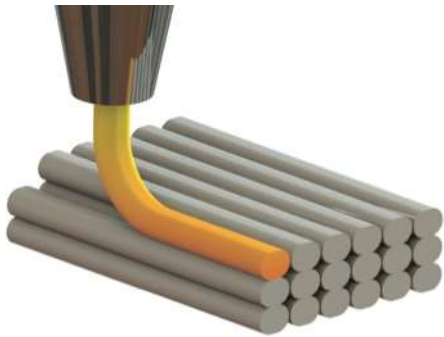

<https://www.additive3d.com/extrusion-deposition-fused-deposition-modeling-fdm/>



28 <https://www.3dhubs.com/knowledge-base/introduction-fdm-3d-printing>

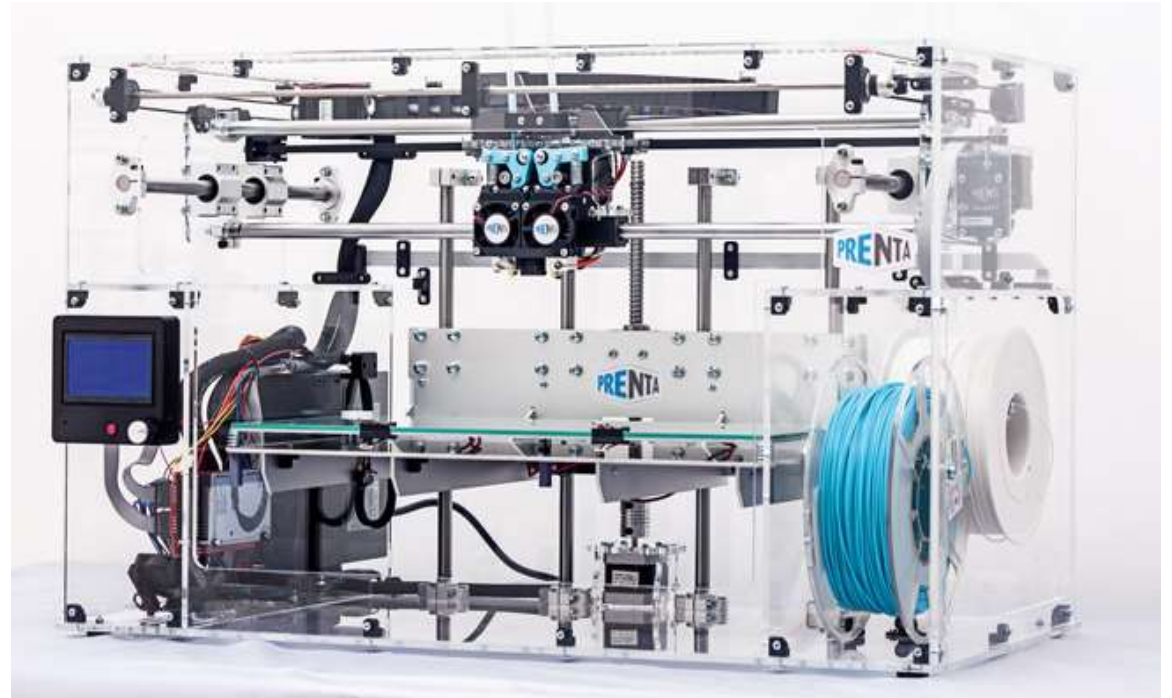

<https://shop.prenta.fi/laitteet-palvelut/3d-tulostimet/prenta-duo-xl>



Binder jetting

- 3D inkjet printer
- Powder bed and binding agent injection
- Powder supports – no need for support structures
- Multi-color printing with plastic
- Casting mold printing – large printers!
- Metal printing
 - Sintering in furnace

FIRPA:

”Process category in which a liquid bonding agent is selectively deposited to join powder materials, to form the object. The liquid bonding agent remains on the surface of the final object. Although the binder reacts at room temperature, it must cure in the powder bed for a few hours before the parts can be removed.”

<http://www.firpa.fi/html/english.html>

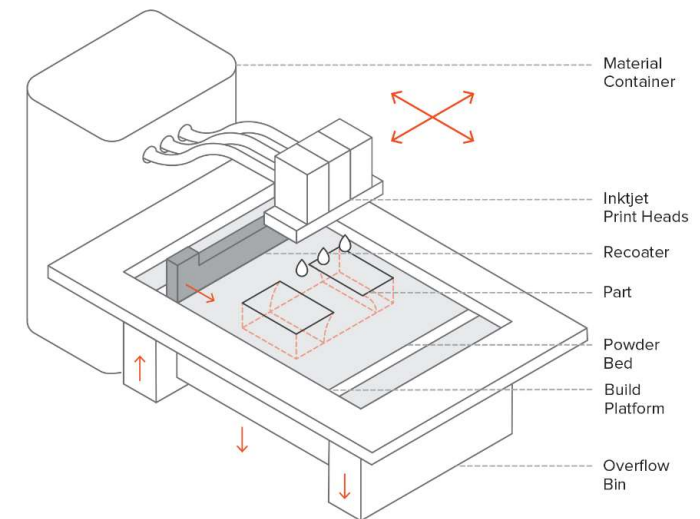
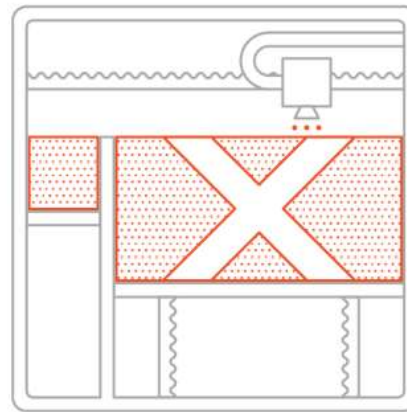
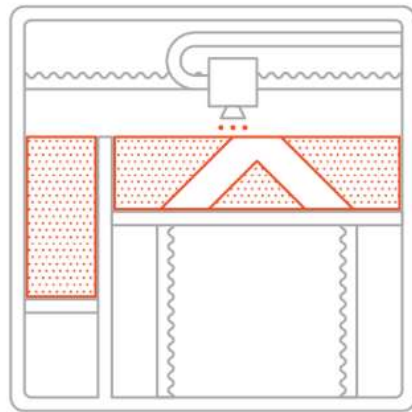
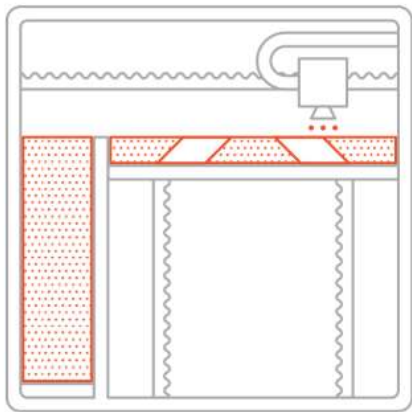

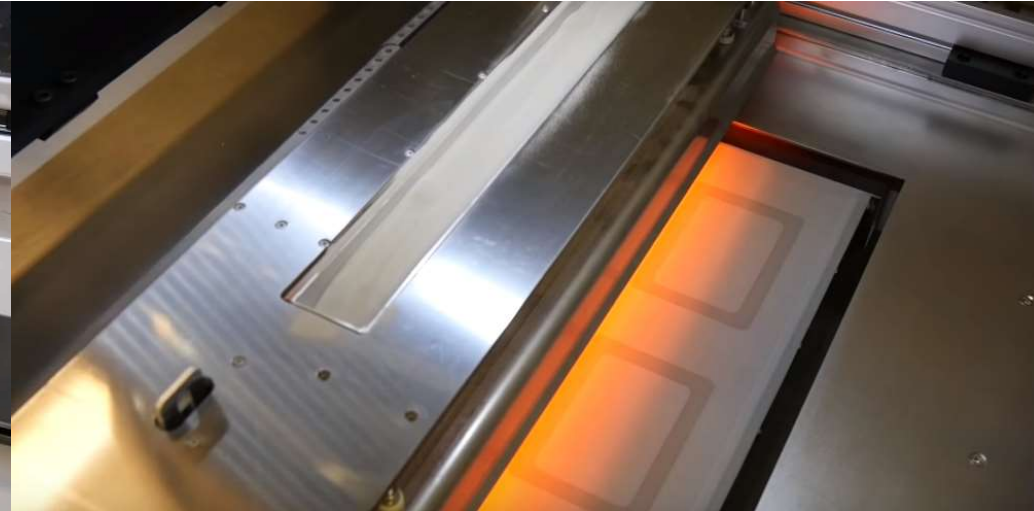
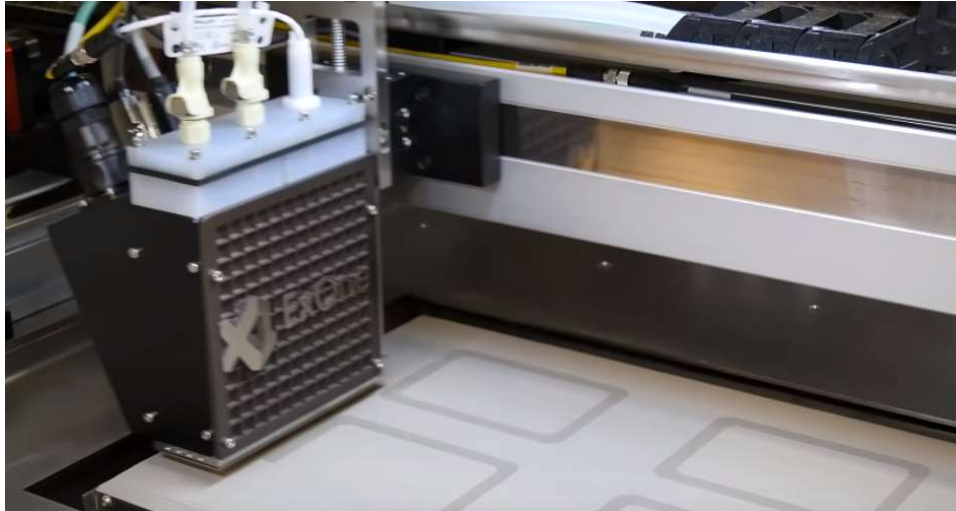

<https://www.exone.com/Resources/Technology-Overview>



Material jetting

- Printing of UV hardened materials
 - waxes and photopolymers
- Injection of material droplets
- Large variety of materials
- Printing of multi-materials is possible
- Relatively good accuracy and surface quality
- "Light sensitivity" and mechanical properties

FIRPA:

"Process category in which droplets of build material are selectively deposited onto the build surface, as one or more print heads move across the build area. Example materials include photopolymer and wax, often kept in material cartridges."

<http://www.firpa.fi/html/english.html>

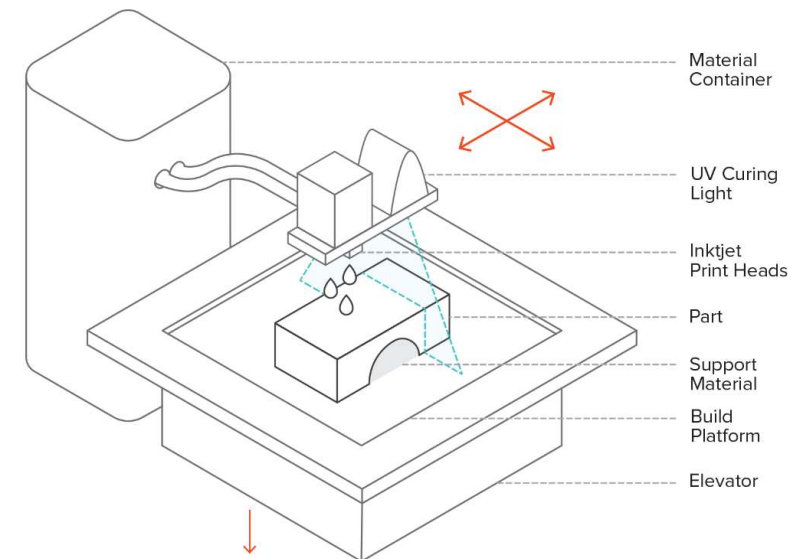
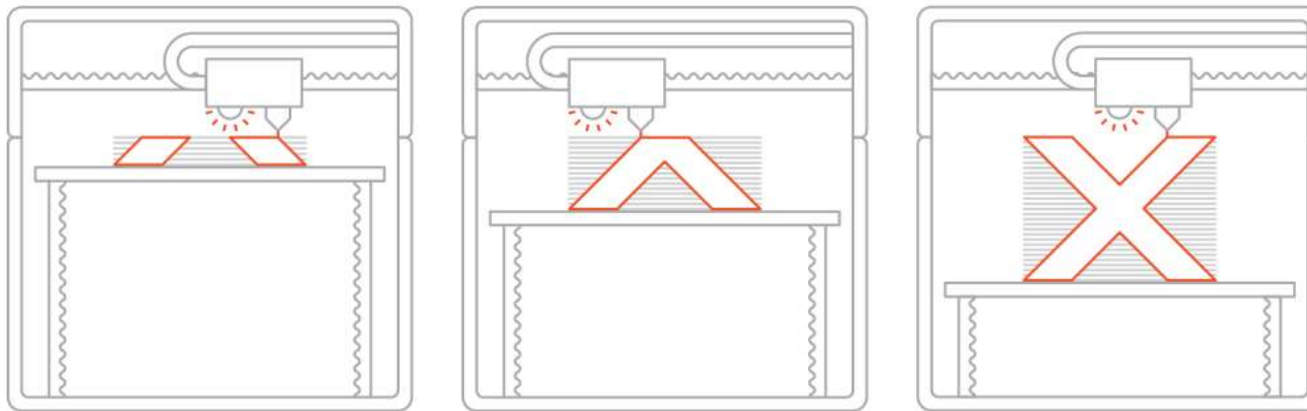



Stereolithography

- Oldest of the 3D printing methods
- UV hardened polymer resin printing
- Good accuracy and surface quality
- "Light sensitivity" and mechanical qualities
- Support structures made from the same material as the product

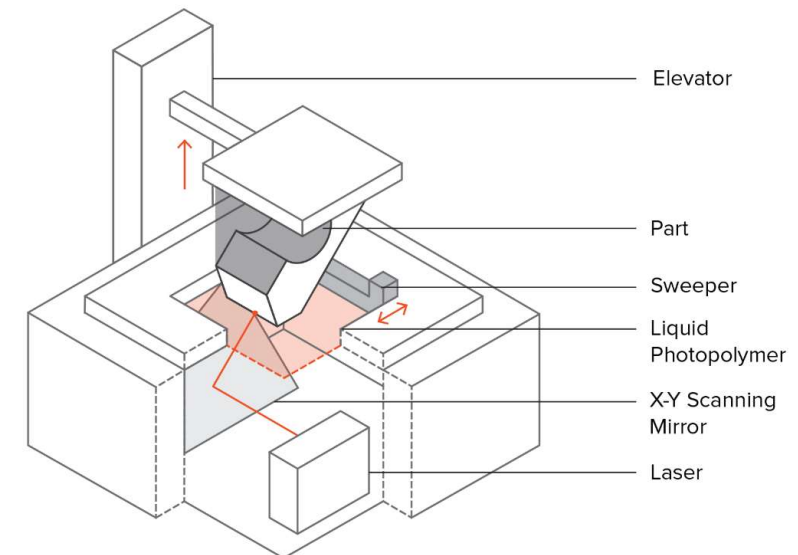
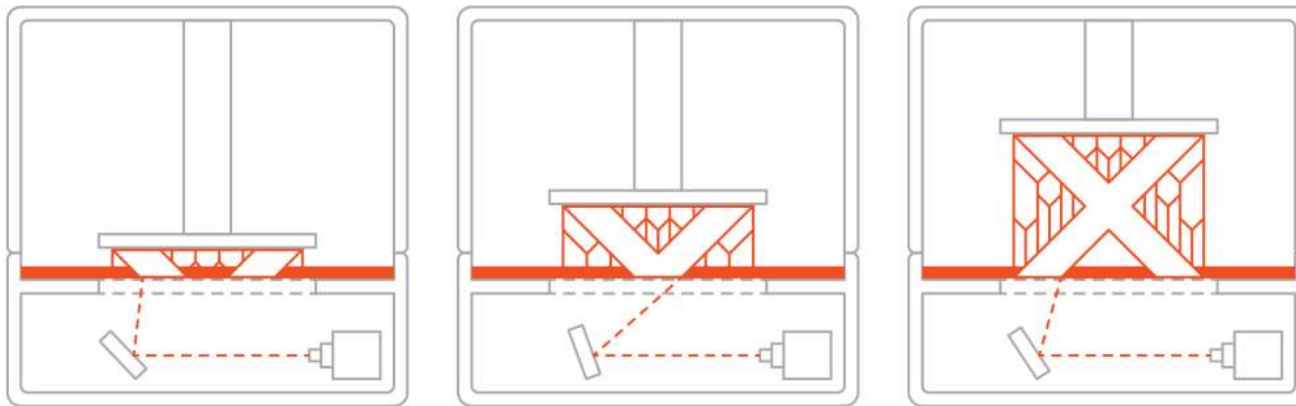

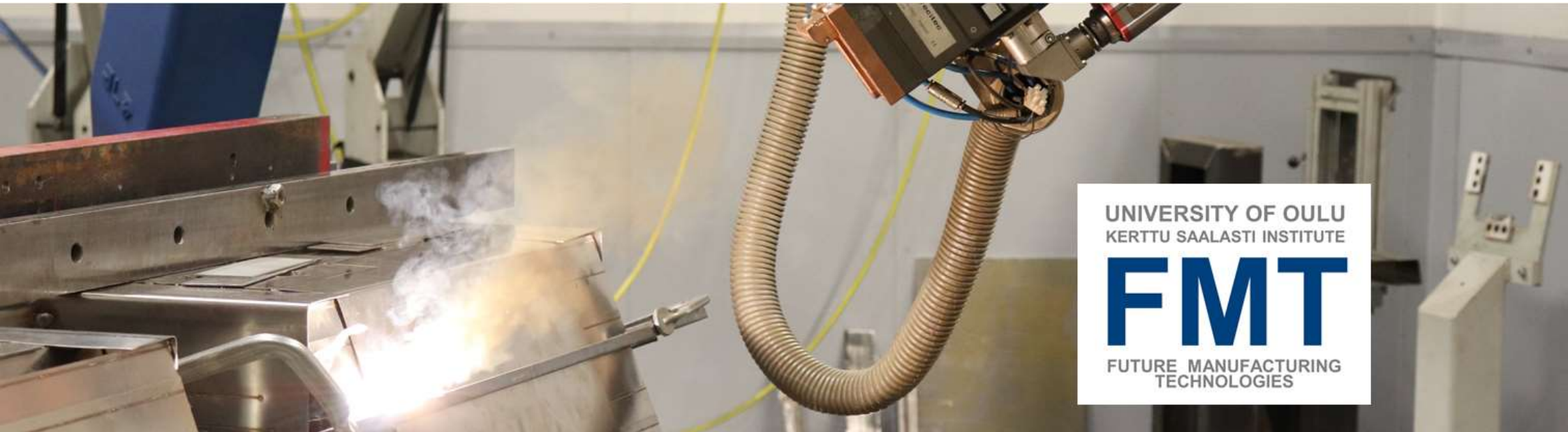

UNIVERSITY OF OULU
KERTTU SAALASTI INSTITUTE
FMT
FUTURE MANUFACTURING
TECHNOLOGIES





- Powder bed
- The green compact

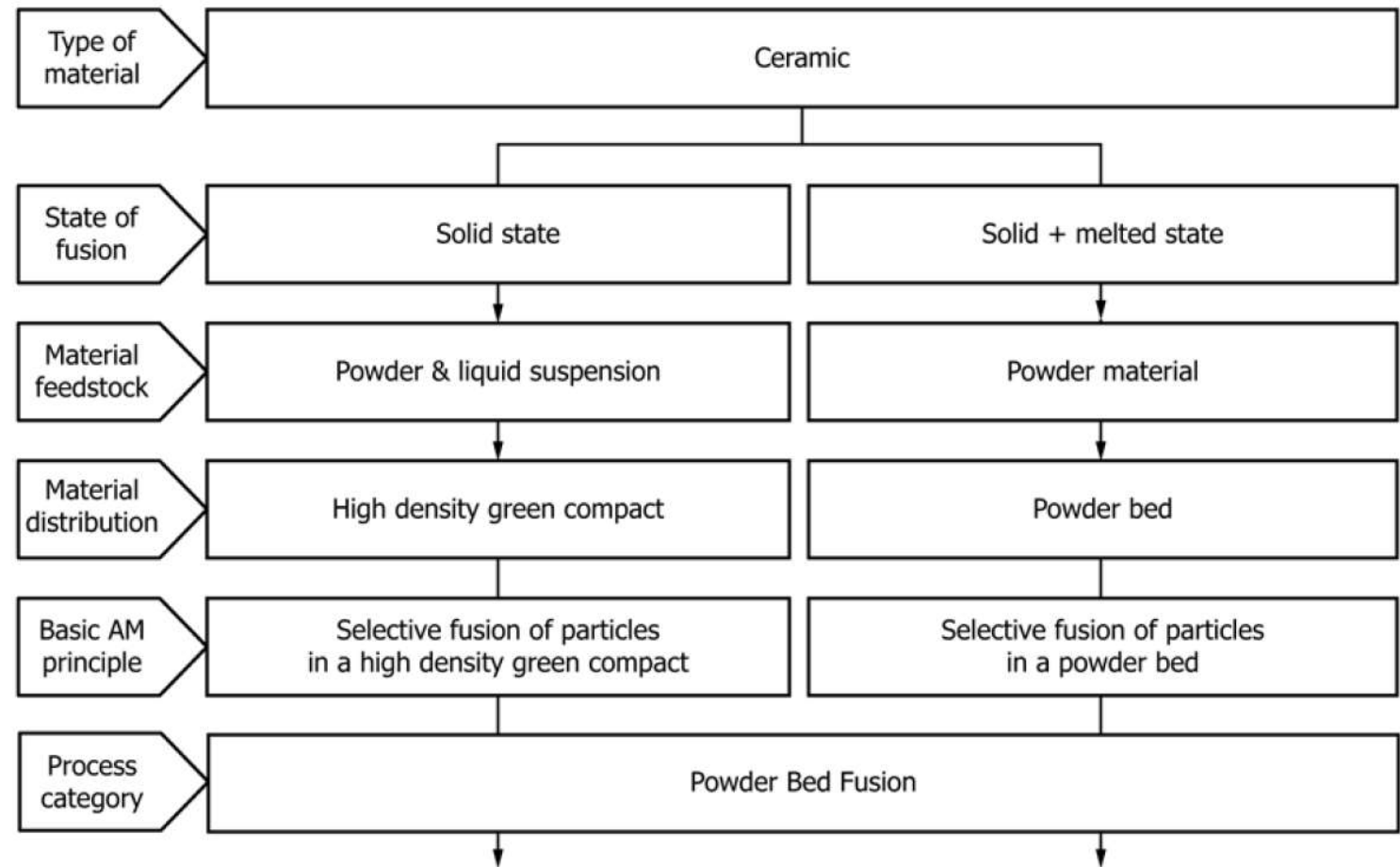

FIG. A1.4 Overview of single-step AM processing principles for ceramic materials





Multi step AM processing

- Metals, ceramics and composites
- Typically during the first phase, the printed material is bound by the medium
- In the following steps the medium disintegrates, usually with the help from heat treatment
- Lastly the piece is sintered. During this process the filler material can be absorbed
- HIP – Hot Isostatic Pressing (400-2070 bar) and c. 2000 °C treatment is used to compress the part

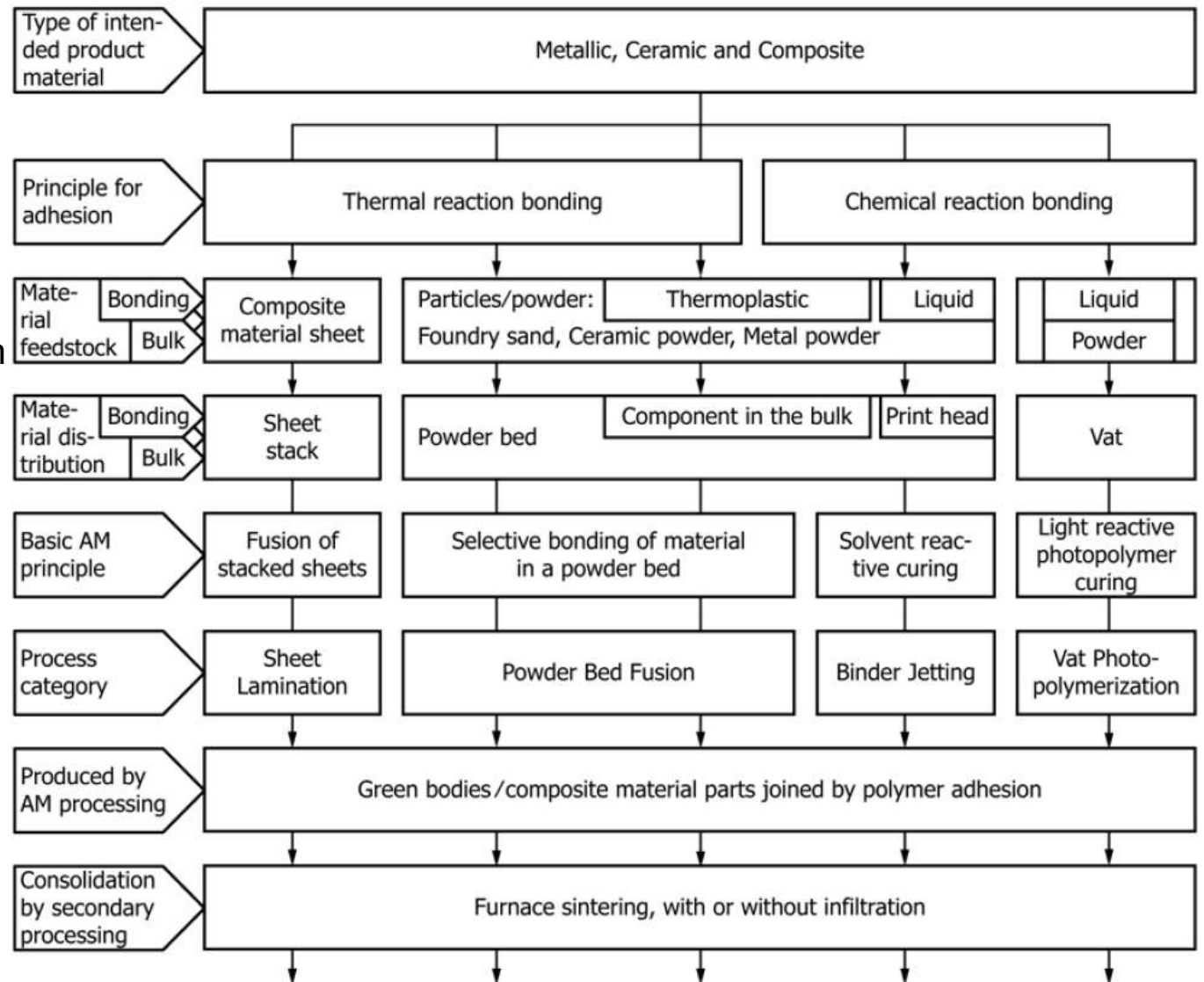

FIG. A1.5 Overview of multi-step AM processing principles for metallic, ceramic and composite materials



ISO/ASTM 52900:2015(E)



REVISION and DISCUSSION

Powder Bed Fusion

Material Extrusion

Vat Photopolymerization

Material Jetting

Binder Jetting

Directed Energy Deposition

Sheet Lamination

- **NEED OF SUPPORT STRUCTURES**
- **NEED OF POST-PROCESSING**
- **ANISOTROPY OF PRINTING**
- **GEOMETRIC LIMITATIONS**
- **MATERIALS AND THE MECHANICAL PROPERTIES OF THE PRINTED PARTS**



UNIVERSITY OF OULU
KERTTU SAALASTI INSTITUTE

FMT

FUTURE MANUFACTURING
TECHNOLOGIES



UNIVERSITY OF OULU
KERTTU SAALASTI INSTITUTE

FMT
FUTURE MANUFACTURING
TECHNOLOGIES

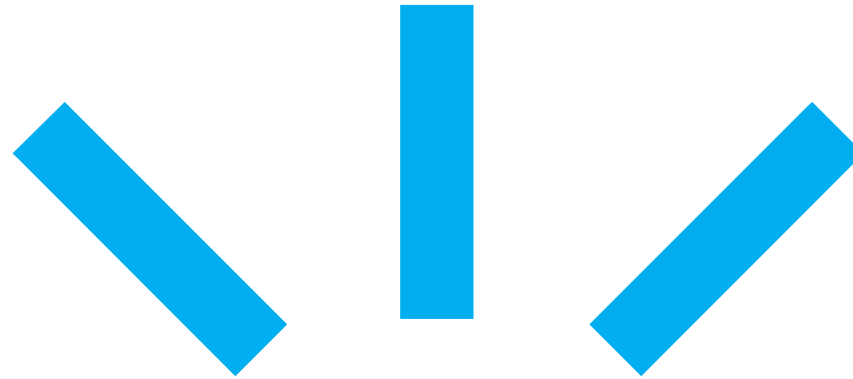

DFAM

**Designing with additive manufacturing in
mind**



Table of contents

- **Example equipment and software**
- **Process**
- DFAM
- Designing the parts
- Creating the supports and printing parameters (Magics)
- Determining the printing time and price of the product
- Factors affecting surface quality
- Mechanical properties
- Using the SLM 280HL printer
- Procedures after printing
- Post-processing of the parts
- **DFAM**
- Case study: Topology optimization
- Case study: Attaching the parts to an assembly
- **Additional measures**
- Different printing platforms
- Changing materials
- Powder screening station



Example of a machine



- **SLM Solutions 280 HL**
- Freely adjustable parameters and possibility to change the material supplier
- Largest printing capacity 280x280x365 mm³, smallest 50x50x80 mm³
- Layer thickness 20 – 75 µm
- 1 x 700W fiber laser
- Materials: AlSi10Mg, AISI 316L, AISI 420, Inconel 718, CoCr and Ti6Al4V. Grain sizes for steel typically 10-45 µm and aluminum/titanium 20-65 µm
- Gas: Argon or nitrogen
- Layer surveillance system: LCS (Layer Control System)
- Additional equipment: MPM (Melt Pool Monitoring), LPM (Laser Power Monitoring) and HTH (High Temperature Heater)
- **Sieving station PSM 100**
- Two different hole sizes on strainer: 75 µm (steels) and 100 µm (aluminum and titanium)
- **Post-processing equipment**
- Glass bead blasting machine, band saw, heat treatment furnace, machinery center, lathe, hand tools...



Machinery and softwares in use

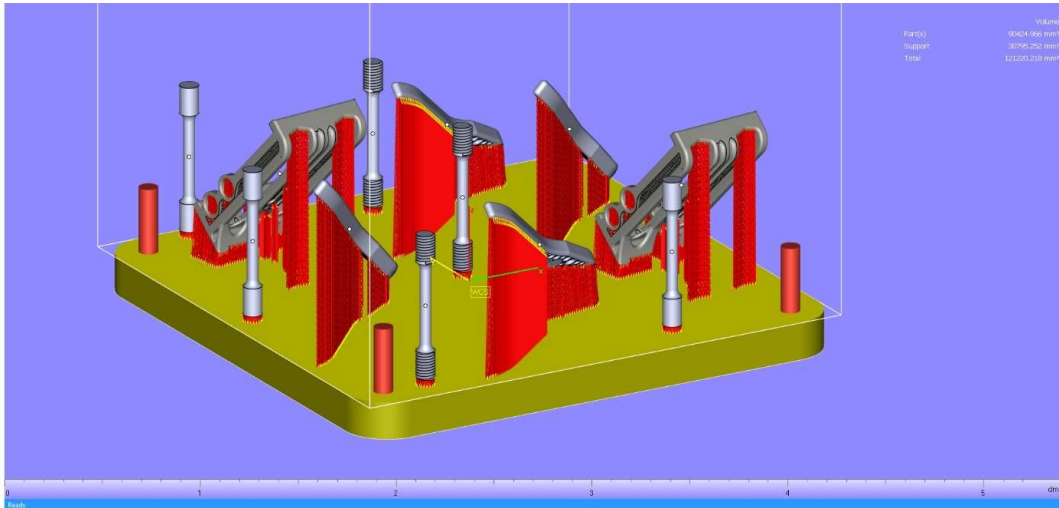

– 3D-desing and FE-analysis

- Modelling a part
- Topology optimization
- FE-analysis
- Saving the file in .STL format

– 3D work plan

- Placing the parts on the platform (“nesting”)
- Creating support structures for the parts (shown as red on the picture)
- Adjusting the machining parameters
 - Laser power and speed, layer thickness
 - Saving the platform and parameters to a target machine compatible format (.SLM format)
- Work planning software for 3D printing
 - Autodesk Netfab
 - Materialise Magics
 - Etc.

– Simulation of printing

- To determine laser trajectory in different printing layers
- To see how parameters are work on different parts of the printed product

– Preparations for printing

- Bringing the platform for printing
- Adjusting temperature for the platform
- Minimum time between layer layouts (Cooling time)
- Adjusting gas flow
- Preparations for the first layer
- Machine software with help from MCS



Process - DFAM



- **DFMA = Design for additive manufacturing**
- **Designing the parts with the manufacturing method in mind is very important!**
- **Geometric freedom – Breaking old habits and traditional models!**
- **Manufacturability, reliability and cost optimization**

- **In the design process:**
 - Geometrical FEM based optimization – strength and weight optimization (Case study)
 - Reducing the amount of parts by combining them – Cutting costs from component manufacturing and the assembly especially (Case study)
 - Diversity of the structure – e.g. honeycomb, web and pore structure utilization
 - Mass tailoring – each part can be different
 - Multi-material printing (not yet available in metal printing) – different properties/materials in the same printed product
 - Consideration of printing position and supports already in the design phase → minimizing post-processing



Process – Designing components

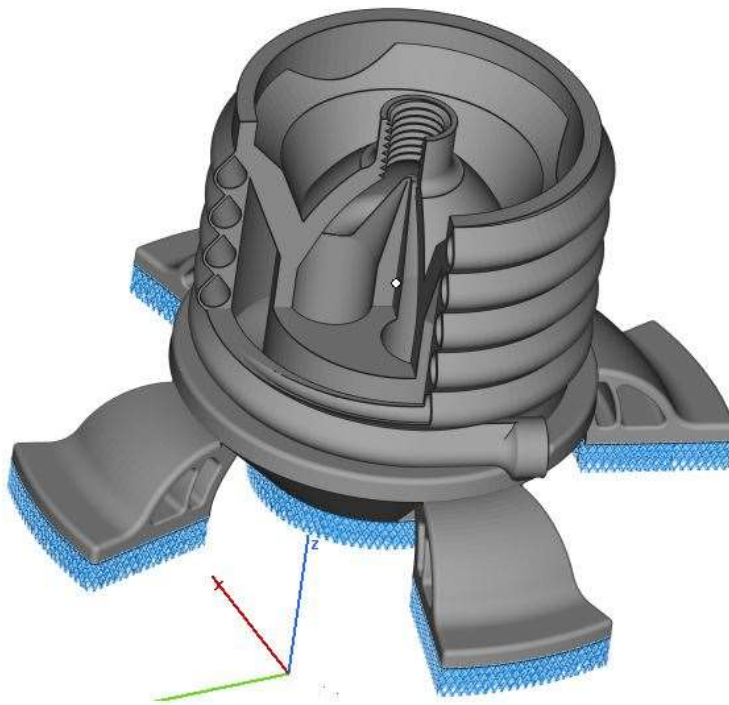

- If a component can be manufactured with traditional methods cost-effectively, it may not be worth it to print it with the SLM method
- **Good 3D printable parts are usually:**
 - Able to make most of the technique's capabilities
 - Structurally more difficult or impossible to manufacture with other methods
 - When multiple parts can be combined into one whole assembly
 - Prototype, small series and individual parts
 - Individual and personalized parts



Process – Designing components

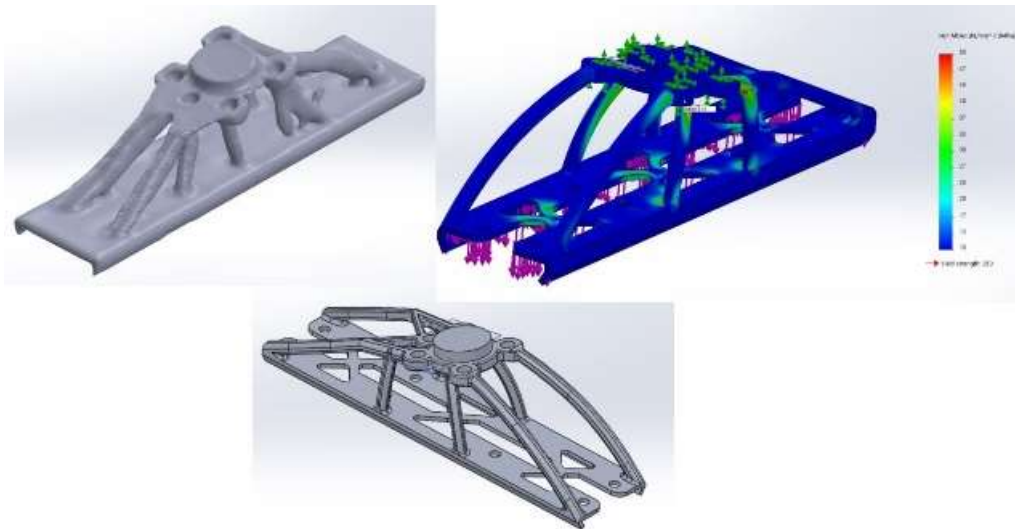

- In addition to the technical requirements, it is important to think through the special characteristics of the printing method and the need for post-processing
- It is important to consider the printing direction and its effects on the part during the design phase
- Topology optimization is a good tool for optimizing strength and weight of the part pictured
- **Design guides:**
 - Standards:
 - ISO / ASTM52910 – 17: Standard Guidelines for Design for Additive Manufacturing
 - VDI 3405 Part 3: Additive manufacturing processes, rapid manufacturing – Design rules for part production using laser sintering and laser beam melting
 - Free Guidelines:
 - Fraunhofer Institute: DESIGN FOR ADDITIVE MANUFACTURING Guidelines and Case Studies for Metal Applications (http://canadamakes.ca/wp-content/uploads/2017/05/2017-05-15_Industry-Canada_Design4AM_141283.pdf)
 - Reinshaw: Design for metal AM - a beginner's guide (<http://www.renishaw.com/en/design-for-metal-am-a-beginners-guide--42652>)
 - Design Guidelines by Materialize (<http://www.materialise.com/en/manufacturing/materials/design-guidelines>)
 - Erin Komi (VTT): Design for Additive Manufacturing (<http://www.vtt.fi/inf/julkaisut/muut/2016/VTT-R-03159-16.pdf>)



Process – Designing components

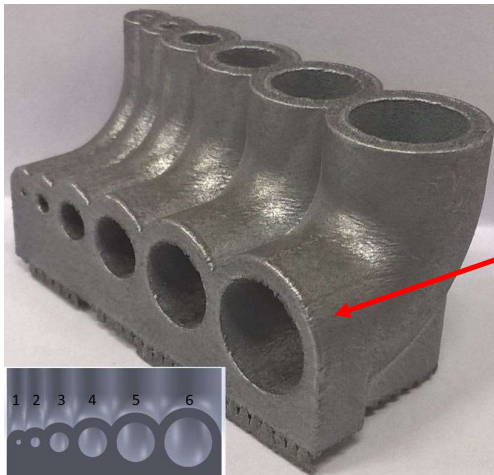

Supports:
AlSi10Mg

Limitations

- Smallest angle without support structures:
 - With steels its 40-45 degrees, depending on the geometry
 - Long and slender rod can twist without supports even in a 45 degree angle
 - Aluminum can be done even in a 30 degree angle
 - Surface quality decreases significantly (gradation effect)
- Circular horizontal hole
 - Steels less than 5 mm
 - Aluminum even up to 10 mm
 - The geometry of a circular hole transforms to a slightly more oval shape
 - Pictured holes 1 mm – 10 mm
- Material restrictions
 - Heat conductivity of aluminum compared to steels
 - Differences in support structures



Supports: 316L



Process – Designing components

- **Purpose of the supports**
 - To transfer the heat brought into the component to the platform as efficiently as possible
 - "Anchoring" the piece into the platform and prevent deformation due to heating
- **A component is suitable for additive manufacturing when**
 - The volume of the support structures is less than that of the part itself
 - The previous layer of the part has to support the next layer → Support structures are avoided

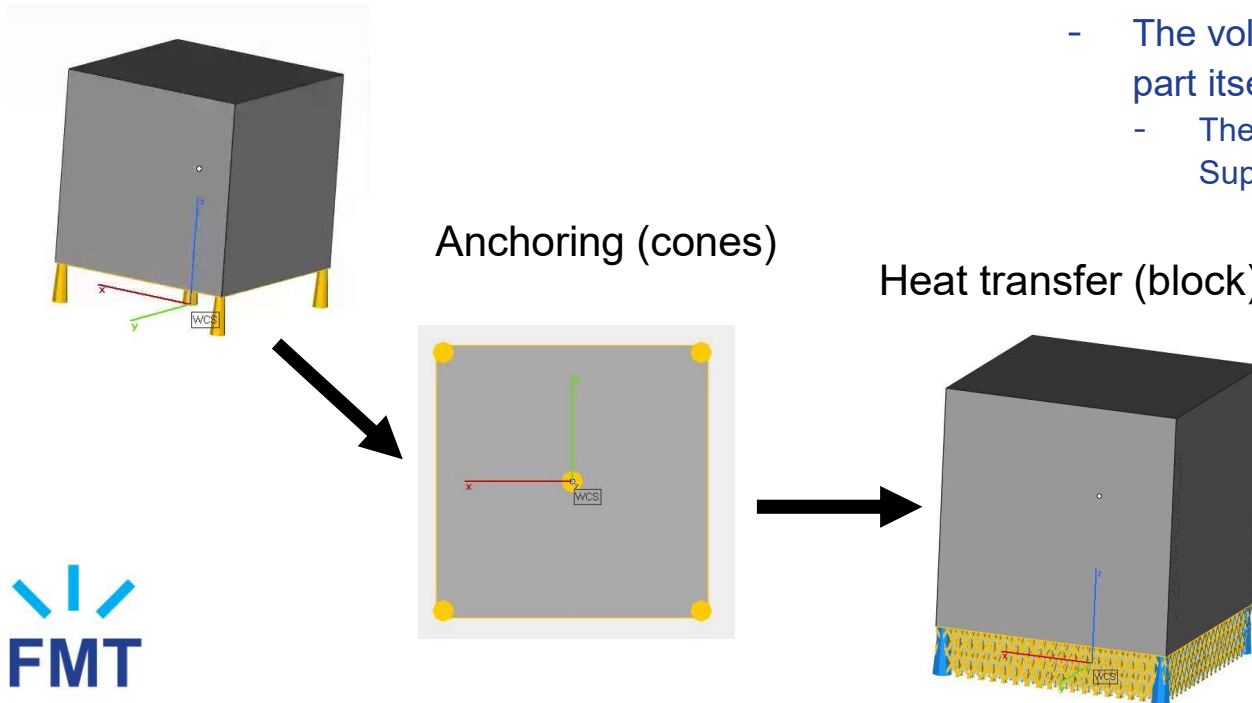



Process – Designing components

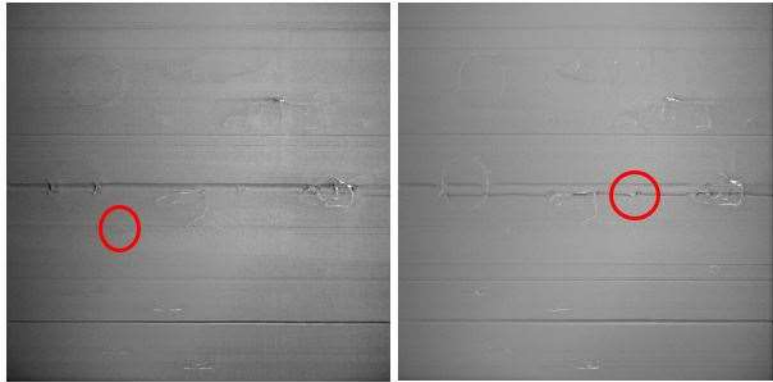

- Pictures show the powder recoating blade colliding with the part (importance of proper design)
- Bad geometry and insufficient support → porous microstructure and unfused powder particles!
- Really poor mechanical properties

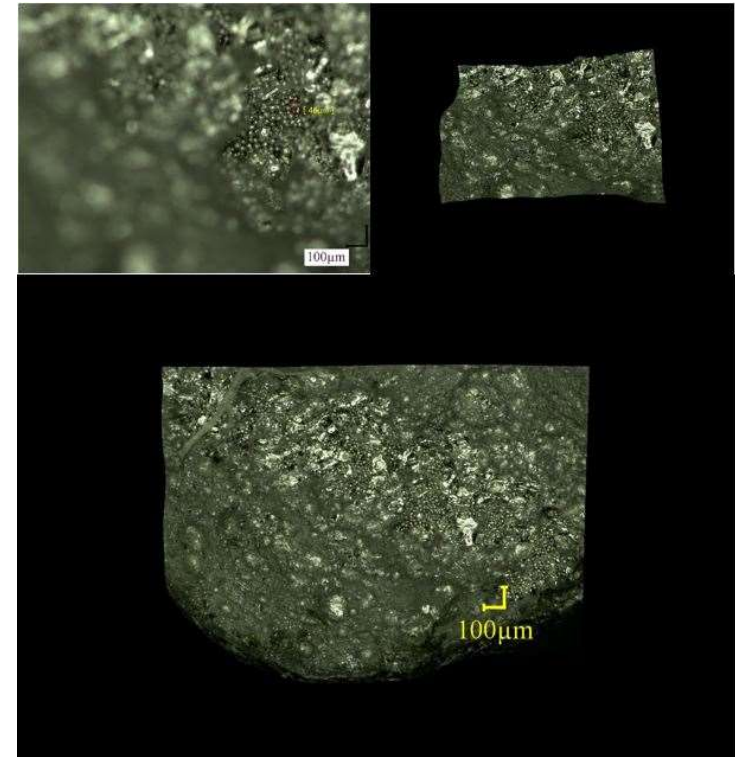



Process – Creating supports and printing parameters

- Transferring parts to 3D printing pre-processing software in STL format
 - Placing the part on the platform
 - Determining component orientation
 - Designing the supports
 - Options for supports e.g. point, line, wedge and wood
 - Different materials have different needs for support
 - Choosing laser parameters/editing them in different sections (picture) e.g.:
 - Laser power
 - Laser processing speed
 - Laser refill settings
 - Selecting layer thickness
 - Creating a configuration file (.SLM)

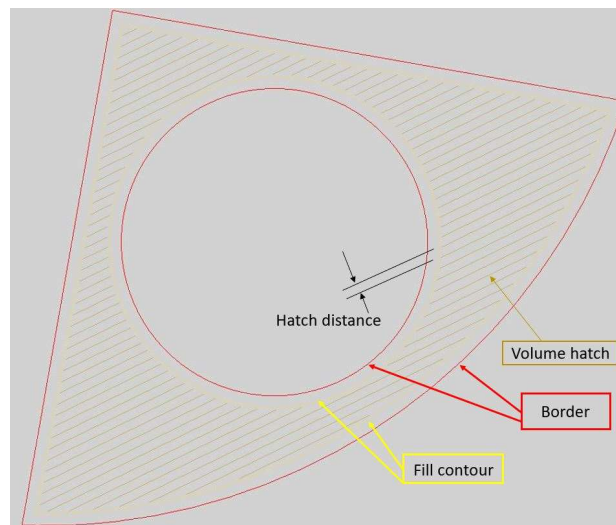



Process – Determining printing time and price of the part

Powder spreading time +
lasering time + cooling time
between layers = **1 layer
printing time**

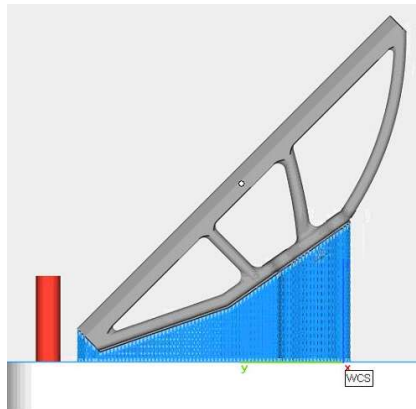

45 deg (30 μm , AlSi10Mg):
Part volume 37203 [mm³]
Support volume 10875 [mm³]
Printing time: 12 h 30 min
Post-processing: easy

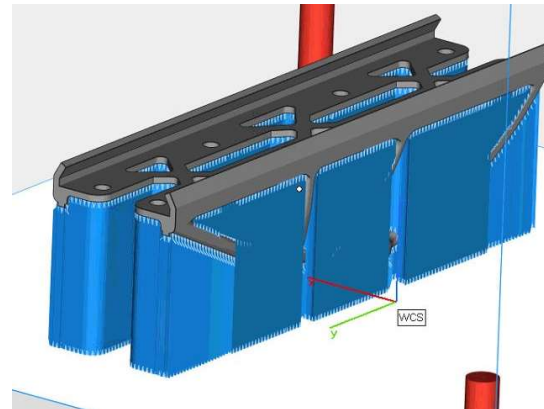

0 deg (30 μm , AlSi10Mg):
Part volume 37203 [mm³]
Support volume 66165 [mm³]
Printing time: 8 h
Post-processing: hard

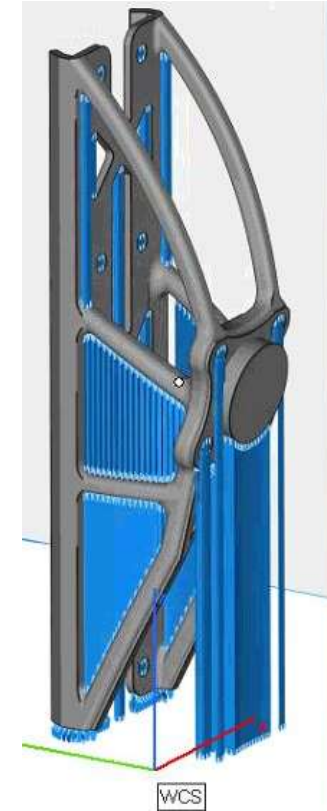

90 deg (30 μm , AlSi10Mg):
Part volume 37203 [mm³]
Support volume 9749 [mm³]
Printing time: 15 h 30 min
Post-processing: medium



Process – Determining printing time and price of the part

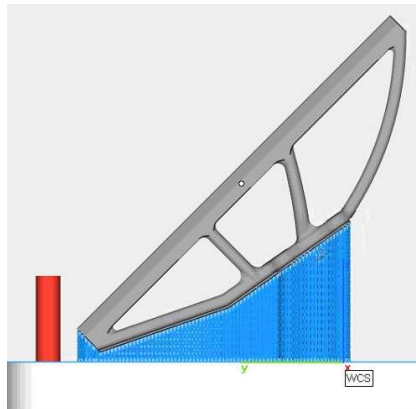

45 deg (30 μm , AlSi10Mg):
Part volume 37203 [mm³]
Support volume 10875 [mm³]
Printing time: 12 h 30 min
Printing cost/part: 1000 € + post-processing

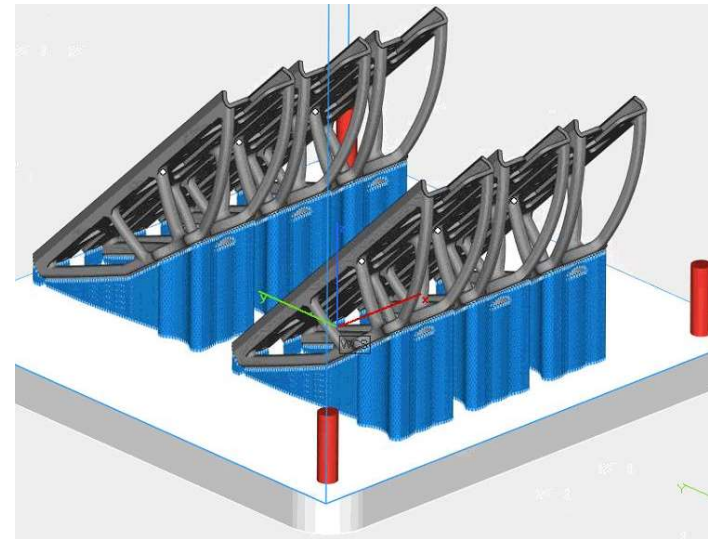

6 kpl 45 deg (30 μm , AlSi10Mg):
Part volume 223218 [mm³]
Support volume 65250 [mm³]
Printing time: 29 h 30 min
Printing cost/part: 393 € + post-processing



Process – Surface quality factors

- **Layer thickness**
- **Geometry of the component**
- Downskin/trailing surface and their angles to the horizontal plane
- Particle size of the metal powder in use
 - Usually:
 - Steels 10-45 μm
 - Reactive materials aluminum and titanium 20-63 μm
- Lasering parameters of the border and downskin





Process – Mechanical properties

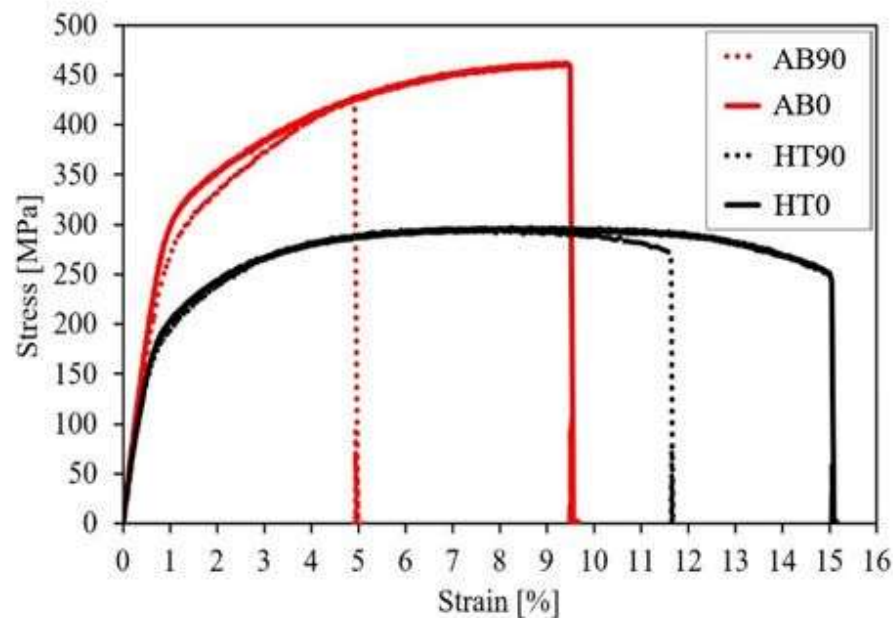

Tensile tests with two directions using AISi10Mg as test material. Both with and without heat treatment.

- **Affecting factors**
- Component's geometry
- Right choice of material
- Anisotropy of material
 - Different printing orientations matter
- Lasering parameters especially on the inside (volume hatch and hatch distance)
- Moisture percentage of the powder < 5 % → Prevents porousness
- Layer thickness

Parameter set	Yield strength [MPa]	Ultimate Strength [MPa]	Uniform Elongation %	Total Elongation %
Set 1	491 ± 2	645 ± 4	16.4 ± 0.1	30.1 ± 0.5
Set 2	504 ± 1	660 ± 2	17.6 ± 0.5	31.8 ± 0.2
Set 3	538 ± 10	701 ± 2	19.1 ± 0.3	33.4 ± 0.4
Reference set	290 ± 3	612 ± 2	47.9 ± 0.2	61.7 ± 0.4

Tensile tests using 316L material with three different parameters. Heat treated.

- Set 1 $E_d = 101 \text{ J/mm}^3$
- Set 2 $E_d = 79 \text{ J/mm}^3$
- Set 3 $E_d = 61 \text{ J/mm}^3$



Process – Mechanical properties

- Monitoring tools LPM (Laser power monitoring) and MPM (Melt Pool Monitoring)
- Machine manufacturers have started to develop different types of software for quality observation
- LPM is used to monitor laser power in real time
 - Notices if nominal output and actual wattage differ significantly
- Gas analyser

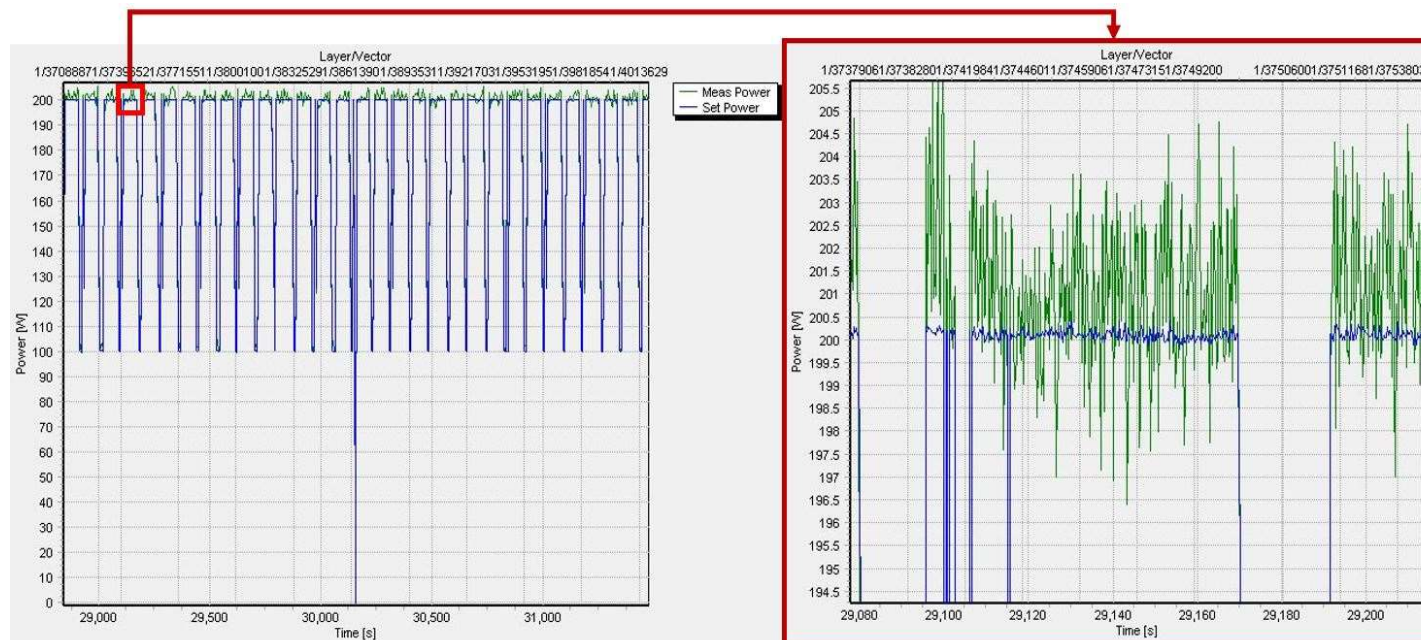



Process – Mechanical properties

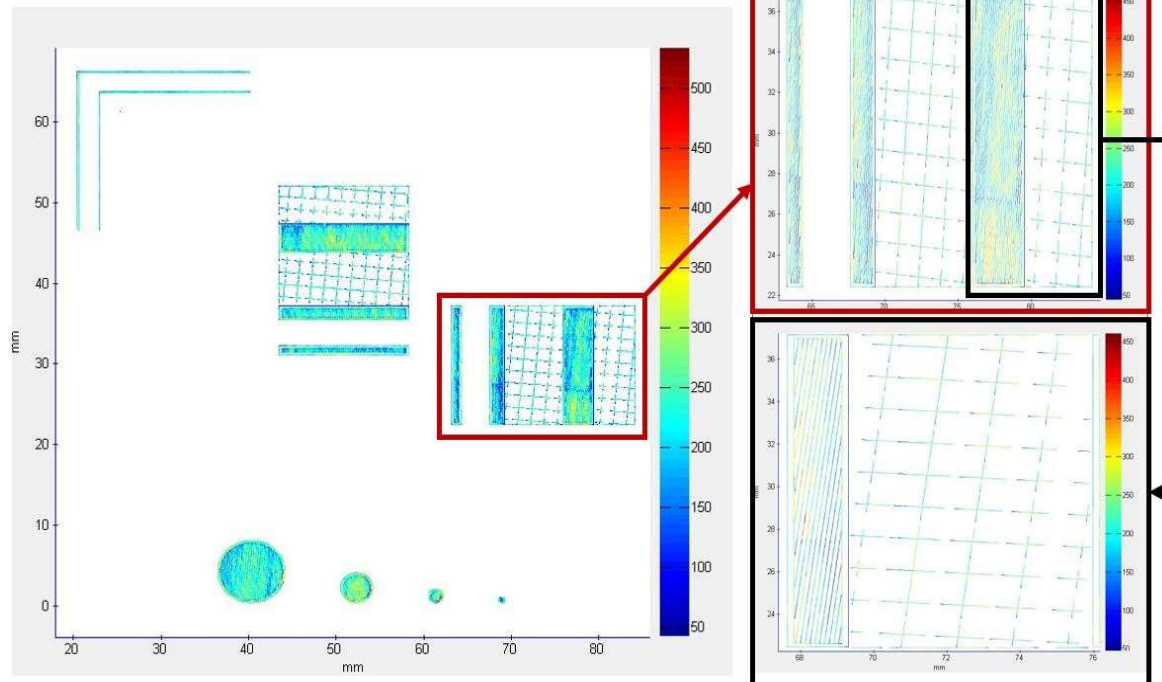

- **Monitoring tools LPM (Laser power monitoring) and MPM (Melt Pool Monitoring)**
- Machine manufacturers have started to develop different types of software for quality observation
- MPM is used to observe the melt pool produced by the laser in real time
 - Picks up on deviations in the melting pool (pores)
 - If one of the components (or its part) has not printed successfully, MPM can be used to determine the fracture area so that it may be redesigned
 - The goal is to obtain perfect heat history of the melt pool



Process – Using the SLM 280HL printer

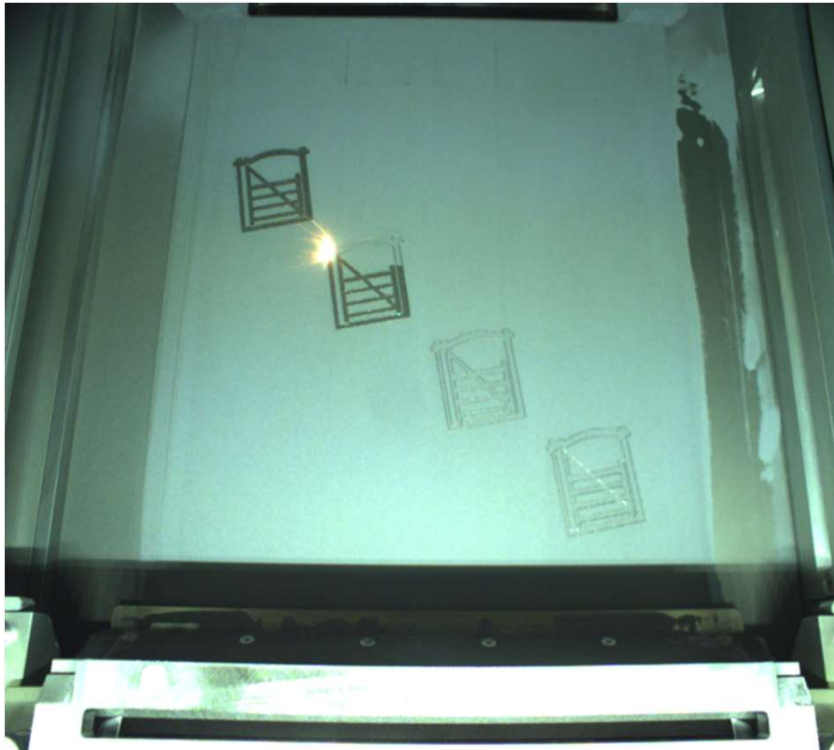

- Exporting the configuration file to the machine's MCS (.SLM)
- Possible machine parameter changes
 - Cooling time between layers
 - Feeding powder
 - Setting flow speed of protective gas (argon, nitrogen)
 - Setting temperature for the platform
- Initial setup
 - Platform and recoating blade calibration to starting height
 - Cleaning of the laser's safety glass
 - Really thin starting layer of metal powder
 - Loading the protective gas into the machine → anoxic state
- MPM launch
- LPM launch
- Starting the machine
- During the printing stage you have to pay attention to:
 - Powder and shielding gas sufficiency, flow of the gas and the even application of the powder



Process – Procedures after printing



- **Once the printing is completed**
 - Recovering the powder from the machine
 - The platform is lifted up manually, so that the powder can be moved (by e.g. brush) to the overflow containers
 - This is repeated until the platform's condition is back to its starting point
 - Sifting the powder
 - Feeding the sifted powder back into the machine (pictured)
 - Separating the platform from the machine
 - Cleaning of the laser's safety glass
 - Detaching the parts from the platform
 - Parts are usually heat treated (removing tension, annealing), when they are still attached to the platform
 - Moving the parts to post-treatment
 - Cleaning the platform from support residue → Platform back to the printer



Process – Post-treating the parts

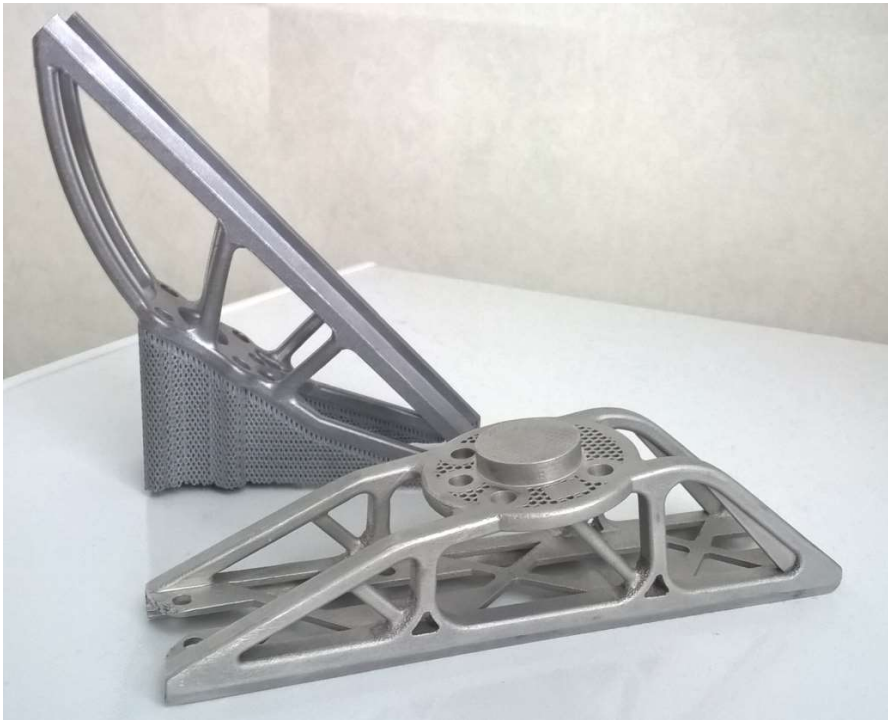

- Usually the components are not ready-to-go right after printing, which means the need to be post-processed
 - Cleaning the part (component + supports) of the powder
 - Heat treated to remove residual stress if need be
 - Detaching the part from the platform and removing the printing support structures
- **Post-processes and methods are for example:**
 - Mechanical removal of the parts from the printing platform, e.g. Electrical and non-electrical tools, power saws, wire saw (wire EDM)
 - Industrial cleaning methods (e.g. ultrasonic cleaner)
- **Machining**
- **Sanding/grinding**
- **Heat treatments**
- Chemical treatments, e.g. **etching**
- **Shot peening and blasting**
- **Coating**



DFAM – Topology optimizing case study robot hand

Step 1:

- Making a mass model
 - Space restrictions
 - Measurements of the mass model
 - Preconditions
 - Attachments
 - Strains/loads

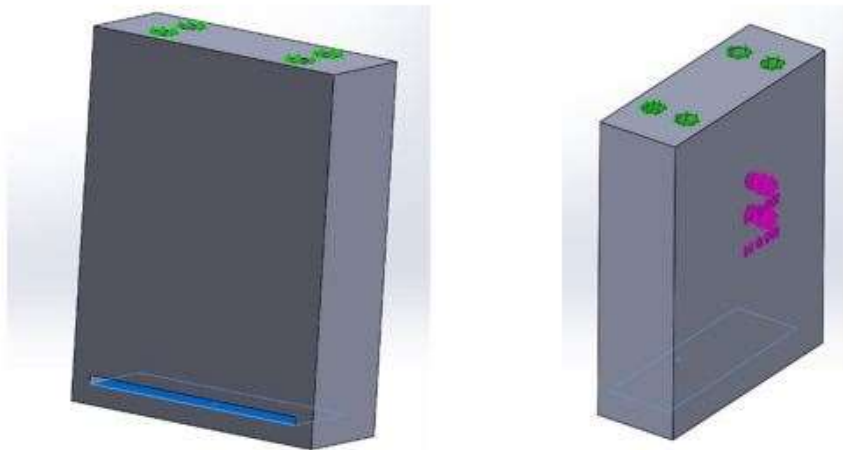



DFAM – Topology optimizing case study robot hand



Step 2:

- First FEM calculation results
 - Optimizing according rigidity and lightness
 - In this case the goal was to make it 75 % lighter
 - Achievement of preliminary results, shown in the picture
 - Path of tension
 - Features of the part
- Does not take into account the manufacturing method → redesign



DFAM – Topology optimizing case study robot hand

Step 3:

- Redesign
 - Taking advantage of the results from the first FEM optimization
 - Also considering the limitations of the manufacturing method
 - Choosing the best orientation (70 degrees from horizontal level), upon which the design will be made on

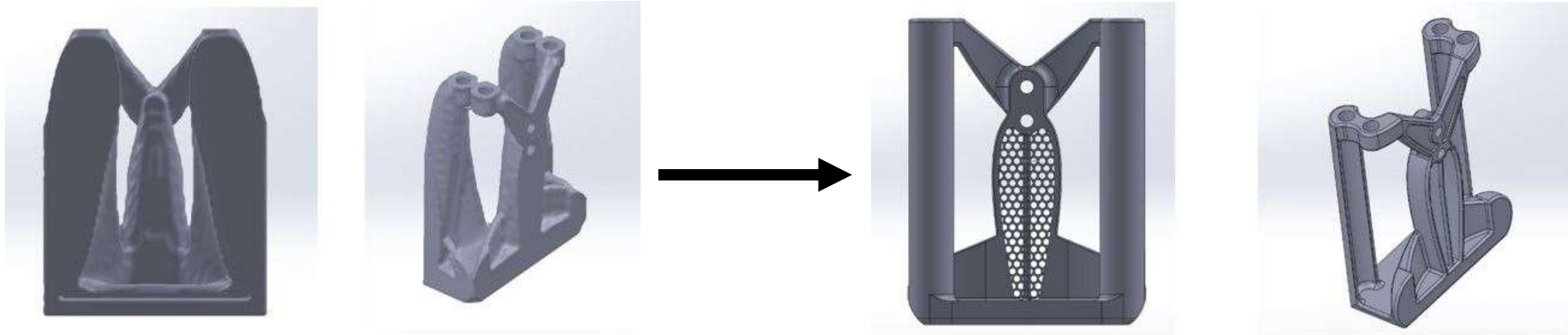



DFAM – Topology optimizing case study robot hand

Step 4:

- Redoing the strength calculation
 - Ensuring the durability of the component...
 - ...and find that its durable!
- Continuing to designing the supports
- Here are the results from this case:

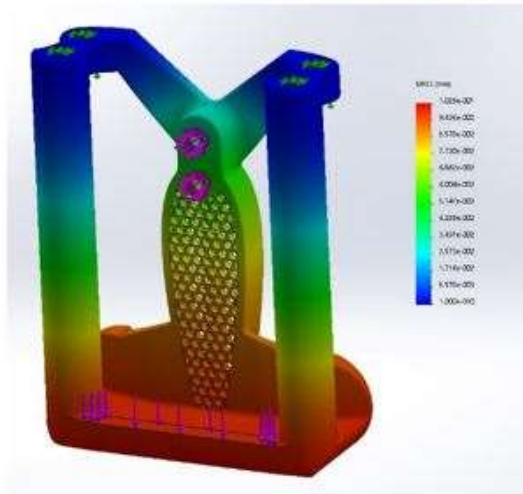
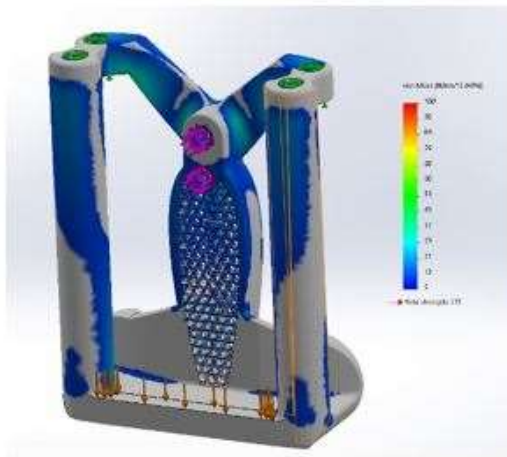

Model	weight [kg]	Measuring tool
Mass model	0.416	Solidworks
Topology optimized	0.077	Solidworks
3D printed part	0.072	Kern FFN scale



DFAM – Topology optimizing case study robot hand

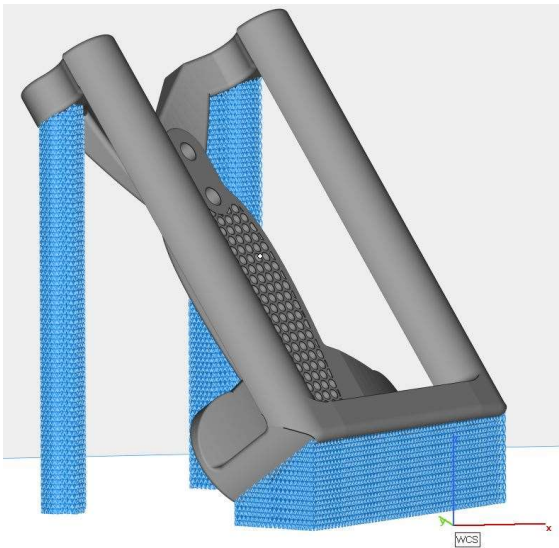

Step 5:

- Creating support structures and process parameters:
 - Orientation has been re-determined for the part during the design phase
 - Selection based on geometry
 - In this case the block-style support was chosen because the areas are large and the structures will be removed
 - Choosing the layer thickness and lasering parameters
- In this case four pieces were printed:
 - Printing time 16 h 30 min
 - Price/part 330 € + post-processing 25 min
 - Machining and glass ball blasting



DFAM – Assembling the part to an entity case study

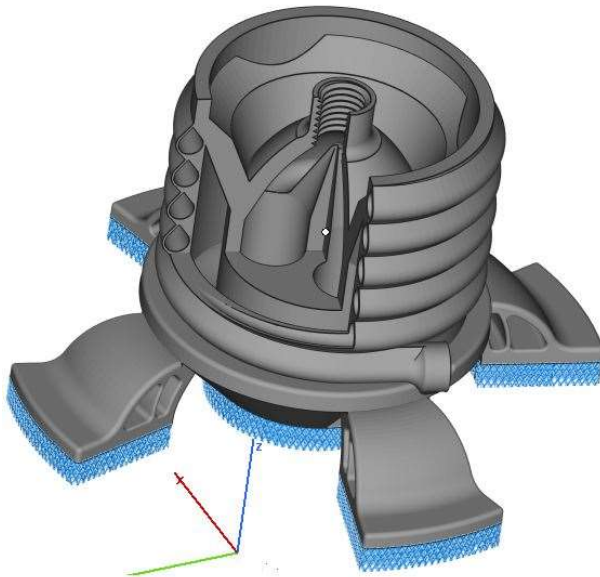

- Material mixer with nozzle structure
 - Three channels merge in the bottom and flow out of the nozzle
- Surrounded by cooling channels
- Chosen material AlSi10Mg for good heat conductivity
- Eight parts connected to one
- Designed so that the previous layer supports the next one → no need for support structure
 - Supports on the bottom for easy removal from the platform
 - Could be printed right on the platform and removed with a wire saw
- Four pieces were printed
- Printing time 29 h → Price for a single part became 580 € + machining



Additional procedures – Different printing platforms

- **Currently there are three different sized platforms available for the printers**
- High Temperature Heater (HTH) platform
 - (round-shaped) diameter 90 mm and printing height 100 mm
 - Maximum temperature 550 °C
 - Over 200 °C temperatures require a ceramic recoating blade. Here the coating is done only in one direction.
 - High temperature are available for titanium and steels
- Reduced platform
 - Printing capacity 50x50x80 mm³
 - No separate heating
 - Reduced platforms are available for titanium, aluminum and steels
- General platform
 - Printing capacity 280x280x365 mm³
 - Temperature max. 200 °C



Additional procedures- Changing the printing materials

Changing the printing materials from steel to steel and from steel to aluminum differ greatly by their work load

- Cleaning between reactive (aluminum and titanium) powders does not require as much work as changing from steels to reactive. Changing steels also does not require cleaning in between.
- For example switching printing material from steel to aluminum calls for changing the filters and cleaning the following:
 - The pipes of the “dirty” line
 - The printing chamber
 - The powder recoating blade
 - The main chamber
 - The powder containers
 - The sift
 - The vacuum



Additional procedures Powder sifting station PSM 100

Separate powder sifting unit PSM 100

- Includes two different sifts: 75 μm (steels) ja 100 μm (aluminum and titanium).
- Sifted again to separate poor particles out of the powder
- Sifting of the "leftover" powder during printing in order to get the fused particles out of the powder





Section summary and discussion

- SLM method in practice
- Designing for the SLM method
- Post-processing and minimizing it
- Lots of materials available - but are they all really usable?

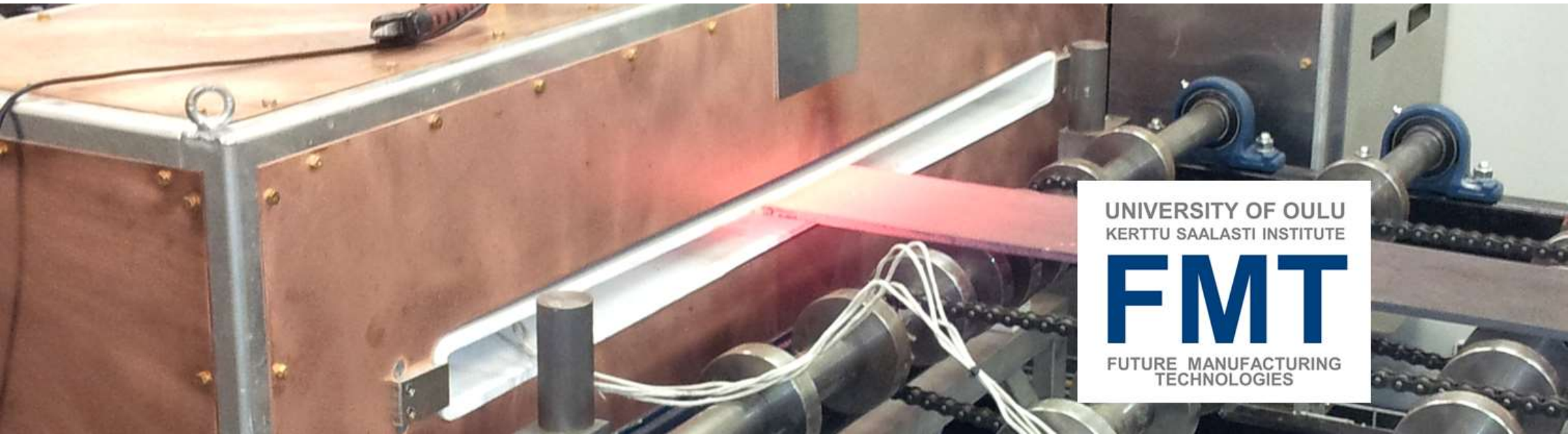

UNIVERSITY OF OULU
KERTTU SAALASTI INSTITUTE

FMT

FUTURE MANUFACTURING
TECHNOLOGIES



UNIVERSITY OF OULU
KERTTU SAALASTI INSTITUTE

FMT
FUTURE MANUFACTURING
TECHNOLOGIES

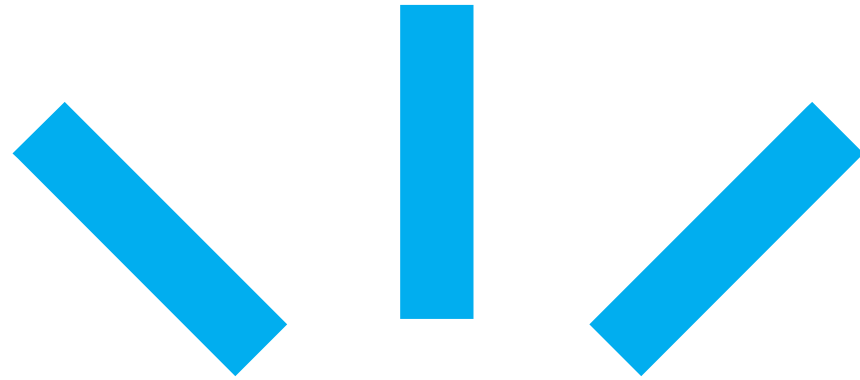

Utilizing AM



What does all this cost?

Machines

Materials

Filters

Gases

Operating costs

Post-processing

– **Machines**

- Plastic printer 300...100 000€
- SLM printer 300 ... 2000 k€

– **Filaments**

- PLA c. 20 €/Kg, Antimicrobial 50 €/kg
- ABS c. 25 €/kg
- Nylon c. 80 €/kg

– **Metal powders**

- 316L c. 42 €/kg
- ALSi10Mg c. 75 €/kg
- Ti6Al-4V c. 310 €/kg
- 18Ni300 c. 80 €/kg



What does all this cost?

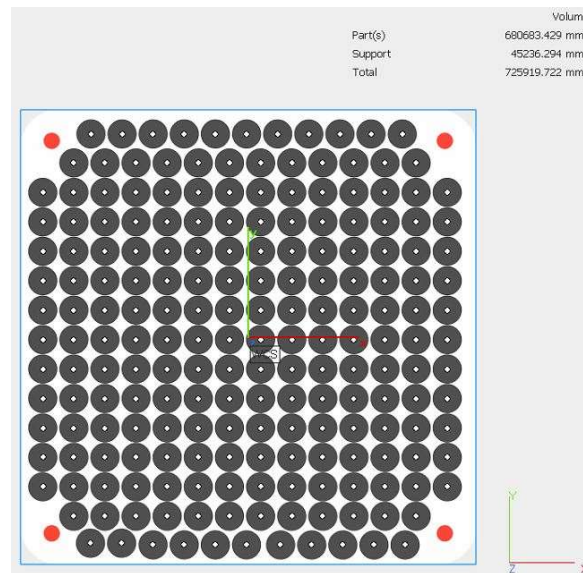
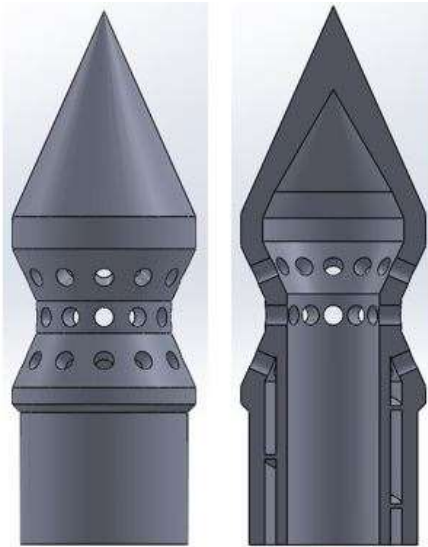

- 200 piece printing of fire nozzles (SLM280HL single 700W laser)
- 725919 mm³ total volume (parts + support structures)
 - Portion of the supports 45236 mm³ (around 6 % of the total volume)
- Printing time 133 h
- Overall printing costs
 - Costs of machine operation 133 h * 100 €/h = 13300 €
 - Cost of materials 573.5 €
 - Post-processing price
- Costs from the printing phase per printed part 13873.5 € / 200 = 69.4 €/part
- Post-processing cost was estimated around 30 €/part (heat treatment, separating part from platform, removal of support structures and lathe work of the O-ring groove)
- Total costs per part 99.4 €
- How to lower the cost even more?
 - Make most of the chamber volume!!



Era of metal 3D printers?

- SLM solutions
- EOS
- Concept Laser
- 3D systems
- Renishaw
- Trumpf
- Mazak (hybrid; metal 3D-printing/CNC)
- DMG Mori
- Arcam
- HP (metal 3D printer on the way)
- Desktop Metal
- Markforged

- Today
 - Amount of lasers in the printers has increased
 - Printing chamber size has increased
 - Increased productivity of the machines
 - Automation of machinery has improved
 - Automatic recycling of powder
 - Automatic cleaning and changing of the chambers
 - Option to use CNC while printing
 - Optimization of printing parameters increased and improved
 - Better quality
 - Monitoring systems for printing for process
 - Faster machines for the market
 - Possibility to make parts faster (if the mechanical properties are not the top criteria)



Future for metal 3D printing?

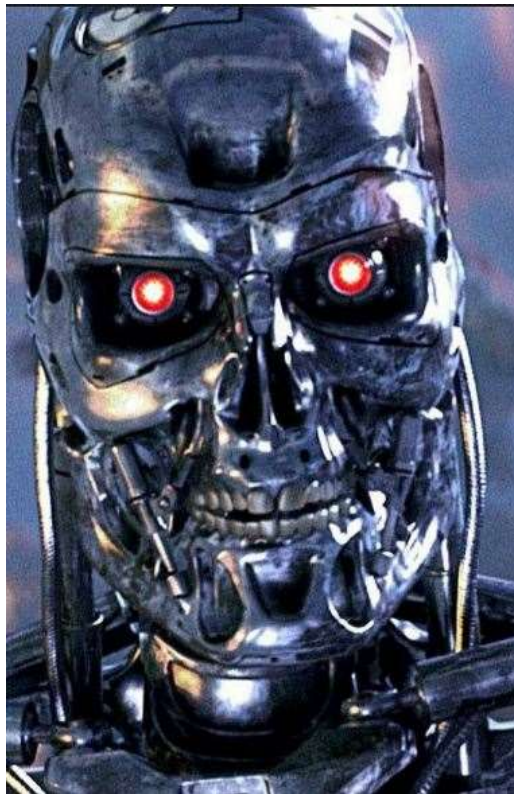

- The future
 - Increased automation of machinery
 - Elimination of support structures
 - Increased machine base
 - Multi-materials for metals as well?
 - Improved quality control
 - The machine can independently improve the quality while printing
 - SLM, DLD, Jetting processes

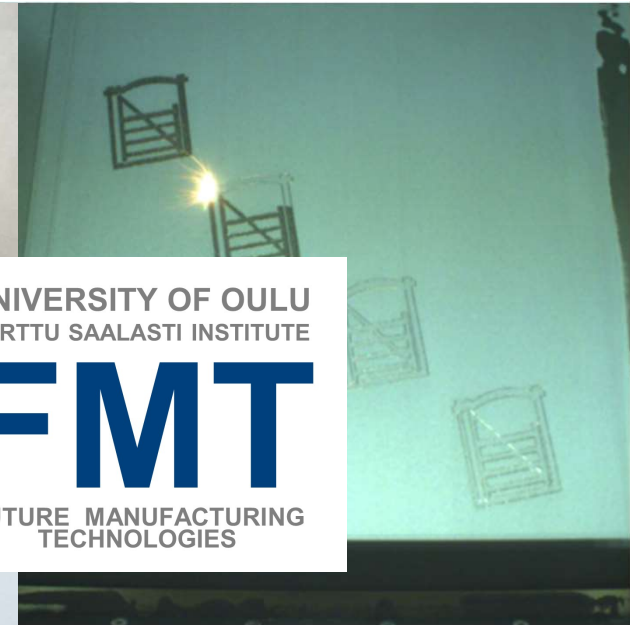
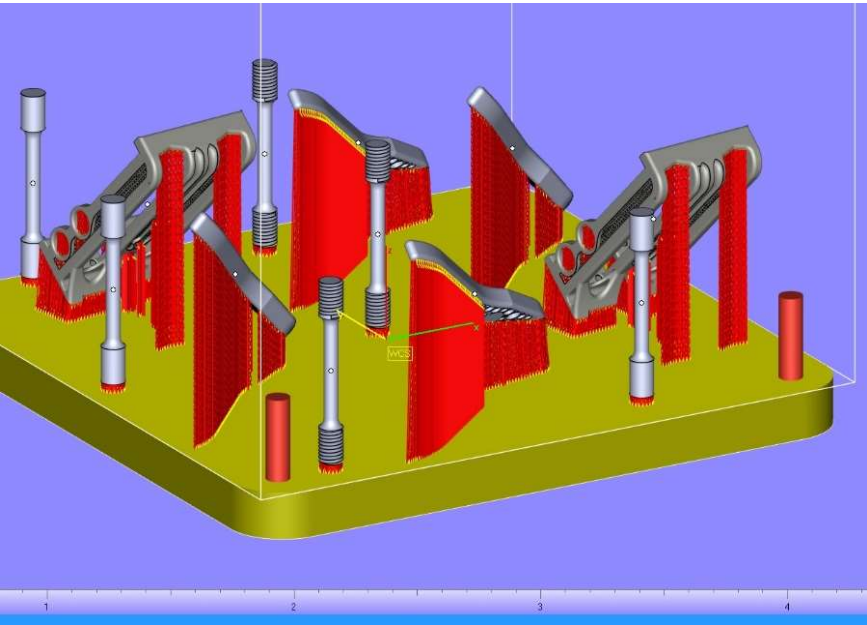

UNIVERSITY OF OULU
KERTTU SAALASTI INSTITUTE
FMT
FUTURE MANUFACTURING
TECHNOLOGIES



UNIVERSITY OF OULU
KERTTU SAALASTI INSTITUTE

FMT

FUTURE MANUFACTURING
TECHNOLOGIES

C3TS

Arctic platform to Create, 3D-print, Test and Sell

In cooperation with



TROMS County Council
TROMS fylkeskommune

**Interreg
Pohjoinen**

Euroopan aluekehitysrahasto



EUROOPAN UNIONI



LAPIN LIITTO

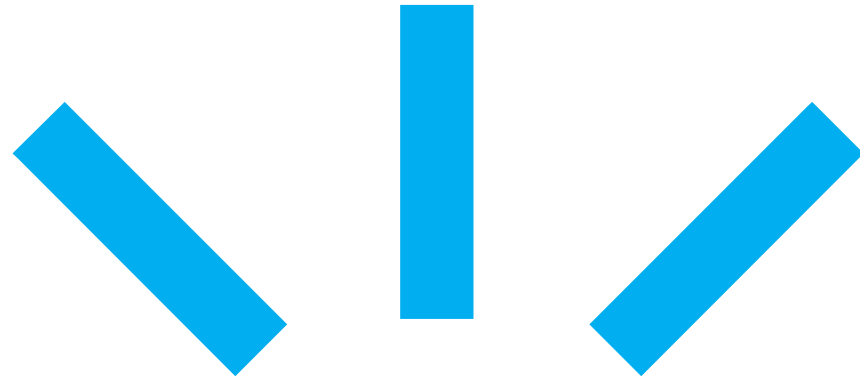

Conclusion and discussion



- 3D printing techniques
- DFAM – Design
- SLM printing in practice
- Industrial utilization and the future
- Discussion and comments



Thank you for your kind attention!



Contact Information:
Research Director Kari Mäntyjärvi
040 084 3050
kari.mantjarvi@oulu.fi

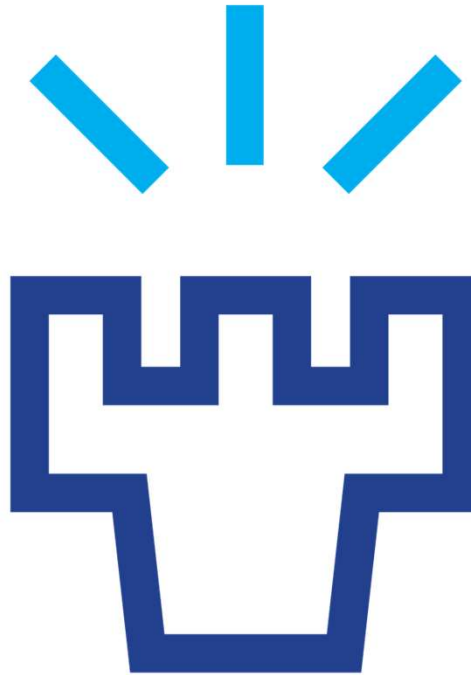

**UNIVERSITY
OF OULU**

FMT
FUTURE MANUFACTURING
TECHNOLOGIES



**UNIVERSITY
OF OULU**

**KERTTU SAALASTI
INSTITUTE**

***Science
With
Arctic
Attitude!***

FMT
FUTURE MANUFACTURING
TECHNOLOGIES

**Contact Information:
Research Director
Kari Mäntyjärvi
040 084 3050
kari.mantjarvi@oulu.fi**